

V-TAC

Meaningful Innovation.

INSTRUCTION MANUAL LED GLASS POOL LIGHT



02 YEAR
WARRANTY*
IP68
RATING

TECHNICAL DATA

MODEL	SKU	WATTS	LUMENS	INPUT VOLTAGE	DIMENSION
VT-1258	217555, 217556	8W	800LM	AC/DC 12V, 50/60Hz	178x110mm
VT-1268	217558	8W	800LM	AC/DC 12V, 50/60Hz	178x110mm
VT-1262	217559, 217560	12W	1260LM	AC/DC 12V, 50/60Hz	178x110mm
VT-1263	217562	12W	1260LM	AC/DC 12V, 50/60Hz	178x110mm
VT-12118	8024	18W	2000LM	AC/DC 12V, 50/60Hz	178x110mm
VT-12125	8025	25W	2850LM	AC/DC 12V, 50/60Hz	178x110mm
VT-12135	8026	35W	4100LM	AC/DC 12V, 50/60Hz	178x110mm

INTRODUCTION & WARRANTY

Thank you for selecting and buying V-TAC LED product. V-TAC will serve you the best. Please read these instructions carefully before starting the installing and keep this manual handy for future reference. If you have any other query, please contact our dealer or local vendor from whom you have purchased the product. They are trained and ready to serve you at the best.

The warranty is valid for 2 years from the date of purchase. The warranty does not apply to damage caused by incorrect installation or abnormal wear and tear. The company gives no warranty against damage to any surface due to incorrect removal and installation of the product. The products are suitable for 10-12 Hours Daily operation. Usage of product for 24 Hours a day would void the warranty. This product is warranted for manufacturing defects only.



This marking indicates that this product should not be disposed of with other household wastes.



Caution, risk of electric shock.

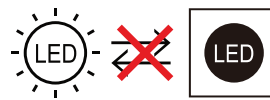

Non-replaceable light source

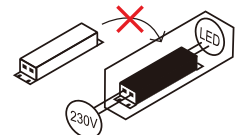

Non-replaceable control gear

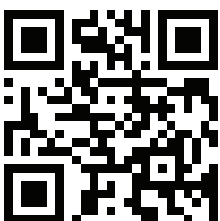

MULTI-LANGUAGE MANUAL QR CODE

Please scan the QR code to access the manual in multiple languages.



FR

Cet appareil, ses accessoires et cordons se recyclent

À DÉPOSER EN MAGASIN

À DÉPOSER EN DÉCHÈTERIE



OU



Points de collecte sur www.quefairedemesdechets.fr
Privilégiez la réparation ou le don de votre appareil !

IN CASE OF ANY QUERY/ISSUE WITH THE PRODUCT, PLEASE REACH OUT TO US AT: SUPPORT@V-TAC.EU
FOR MORE PRODUCTS RANGE, INQUIRY PLEASE CONTACT OUR DISTRIBUTOR OR NEAREST DEALERS.
V-TAC EUROPE LTD. BULGARIA, PLOVDIV 4000, BUL.L.KARAVELOW 9B

WARNING

1. Install only by certified electrician.
2. Please make sure to turn off the power before starting the installation.
3. The light source of this luminaire is not replaceable, when the light source reaches its end of life the whole luminaire should be replaced.
4. Proper grounding should be ensured throughout the installation.

INSTALLATION INSTRUCTIONS

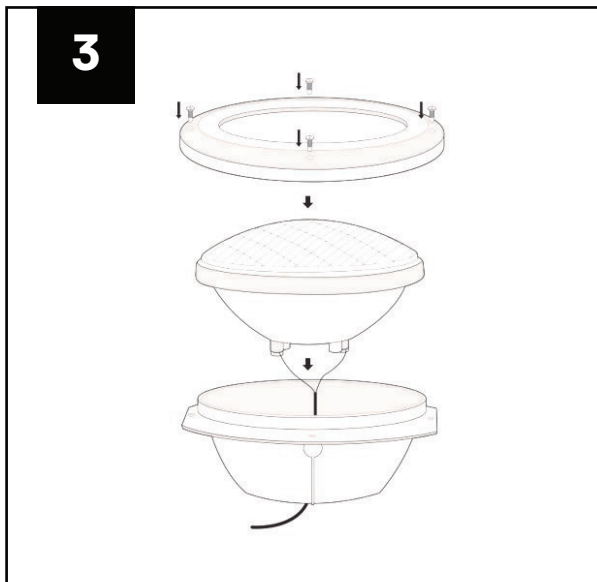
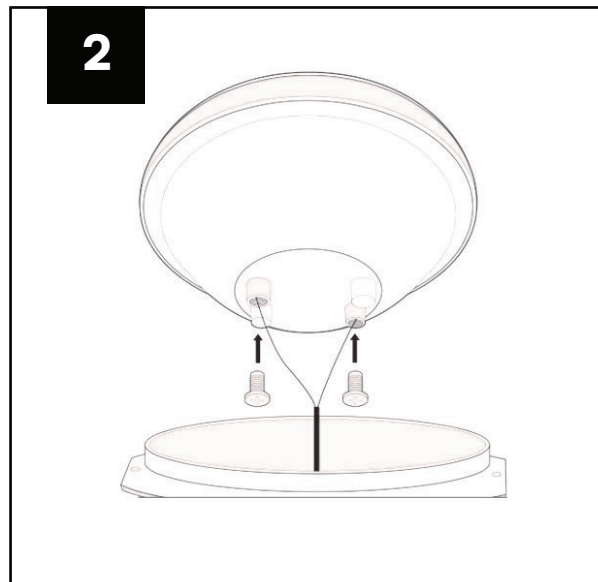
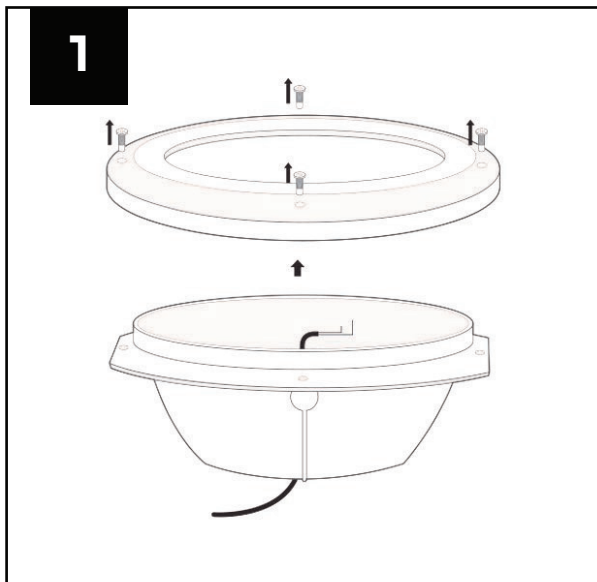

STEP 1

Switch off the power. Take out the pool embedded parts, twist off the screws from the lid, and then take off the lid.

STEP 2

Connect the power output cable of the embedded parts with the terminals of the lamp, and then tighten the screws.

STEP 3

Put the lamp into the embedded parts and cover the lid and tighten the screws. Switch on the light and test.

RoHS



UK
CA

