

V-TAC

Meaningful Innovation.

INSTRUCTION MANUAL LED FLOOD LIGHT



**IP65
RATING**

**3 IN 1
CCT**

TECHNICAL DATA

MODEL	SKU	WATTS	USEFUL LUMEN @WIDE CONE	BEAM ANGLE	LIFE SPAN [HOURS]	DF	CRI	INPUT VOLTAGE	DIMENSION	N.W	MAX MOUNTING HEIGHT	PROJECTED AREA	BODY TYPE	IK RATING
VT-44014CCT	240726	10W	730 Lm	90°	50,000	>0.9	>80	AC: 220-240V, 50/60Hz	147x33x122mm	192g	3-5m	12-34m ²	Aluminium	IK06
VT-44058CCT	240736	50W	4000 Lm	90°	50,000	>0.9	>80	AC: 220-240V, 50/60Hz	227x33x182mm	418g	3-5m	18.5-50.5m ²	Aluminium	IK06
VT-44110CCT	240716	100W	8150 Lm	90°	50,000	>0.9	>80	AC: 220-240V, 50/60Hz	297x33x242mm	825g	3-5m	38-103m ²	Aluminium	IK06
VT-44209CCT	240706	200W	16450 Lm	90°	50,000	>0.9	>80	AC: 220-240V, 50/60Hz	410x33x326mm	1550g	3-5m	100-200m ²	Aluminium	IK06

The operating temperature range for these items is -20°C to +40°C.

INTRODUCTION & WARRANTY

Thank you for selecting and buying V-TAC product. V-TAC will serve you the best. Please read these instructions carefully before starting the installing and keep this manual handy for future reference. If you have any another query, please contact our dealer or local vendor from whom you have purchased the product. They are trained and ready to serve you at the best. The warranty is valid for 6 years from the date of purchase. The warranty does not apply to damage caused by incorrect installation or abnormal wear and tear. The company gives no warranty against damage to any surface due to incorrect removal and installation of the product. The products are suitable for 10-12 Hours Daily operation. Usage of product for 24 Hours a day would void the warranty. This product is warranted for manufacturing defects only.

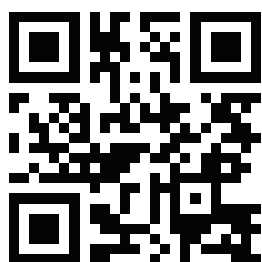

MULTI-LANGUAGE MANUAL QR CODE

Please scan the QR code to access the manual in multiple languages.



FR

Cet appareil, ses accessoires et câbles se recyclent

À DÉPOSER EN MAGASIN

À DÉPOSER EN DÉCHÈTERIE





OU



Points de collecte sur www.quefairedemesdechets.fr
Privilégiez la réparation ou le don de votre appareil !

WARNING

- Please make sure to turn off the power before starting the installation.
- Installation must be performed by a qualified electrician.
- The light source contained in this luminaire shall only be replaced by the manufacturer or his service agent or a similar qualified person.
- The external flexible cable or cord of this luminaire cannot be replaced; if the cord is damaged, the luminaire shall be destroyed.
- Terminal block not included.
- Proper grounding should be ensured throughout the installation.
- For outdoor use.
- Replace any cracked protective shield. 
- Minimum distance from lighted objects 1m. 

NOTE

- To reduce the risk of strangulation the flexible wiring connected to this luminaire shall be effectively fixed to the wall if the wiring is within arm's reach.
- In order to maintain the IP protection of the product, the cable entry/gland should be installed on the bottom side.

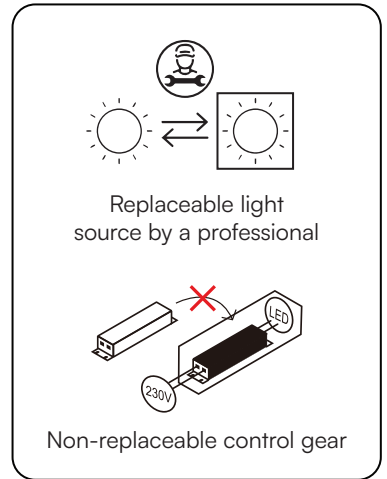

Replaceable light source by a professional

Non-replaceable control gear



Caution, risk of electric shock.



This marking indicates that this product should not be disposed of with other household wastes.

INSTALLATION DIAGRAM

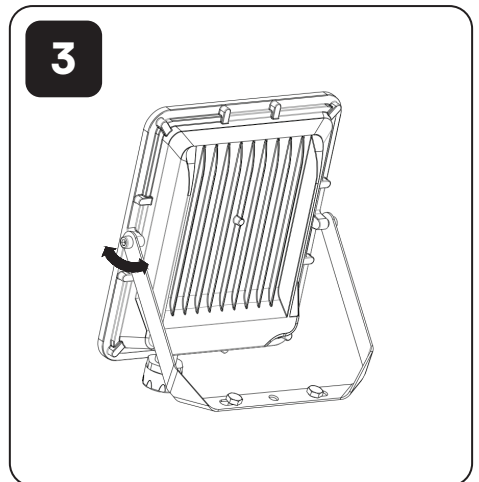
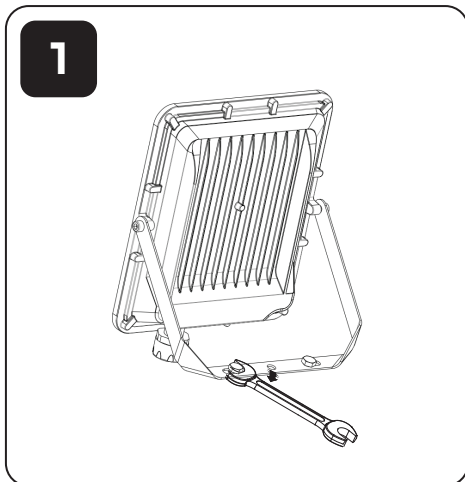
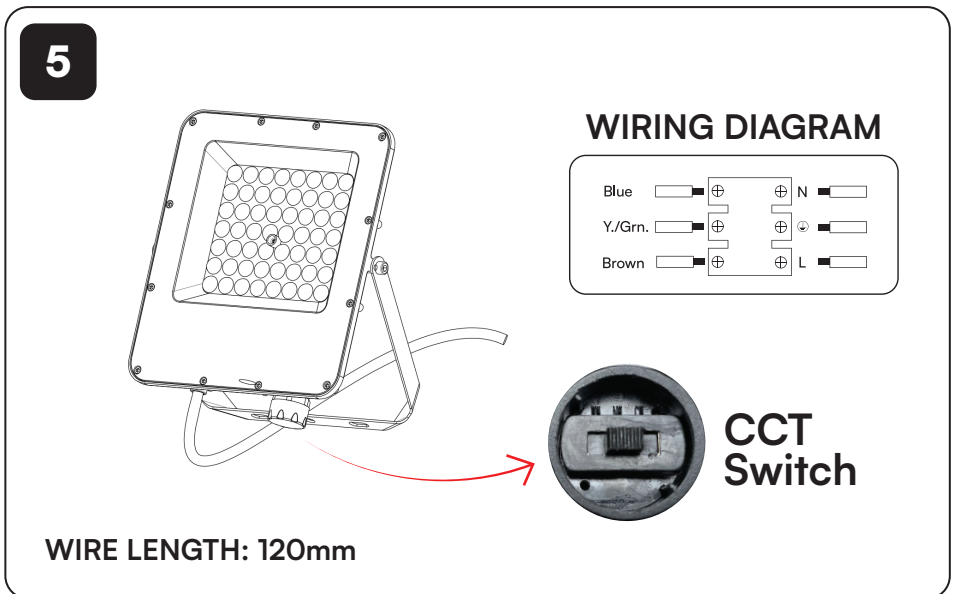
WIRING DIAGRAM

Blue	⊕	⊕	N
Y./Grn.	⊕	⊖	
Brown	⊕	⊕	L

CCT Switch

WIRE LENGTH: 120mm

INSTALLATION INSTRUCTIONS

Important: Strictly follow the steps below during installation. Avoid applying excessive force to the power cable. The supply connection and other external wiring conductors must be at least 3 x 1.0 mm²

- Ensure the power is turned off before starting the installation.
- Secure the brackets to the desired surface.
- Loosen the bolts on both sides of the bracket.
- Adjust the floodlight to the desired angle.
- Tighten the bolts on both sides of the bracket to secure the position.
- Connect the floodlight wiring according to the wiring diagram.
- Set the desired color temperature using the CCT switch.
- Turn on the power and test the floodlight.

DISMANTLING INSTRUCTIONS

(For Market surveillance team only)

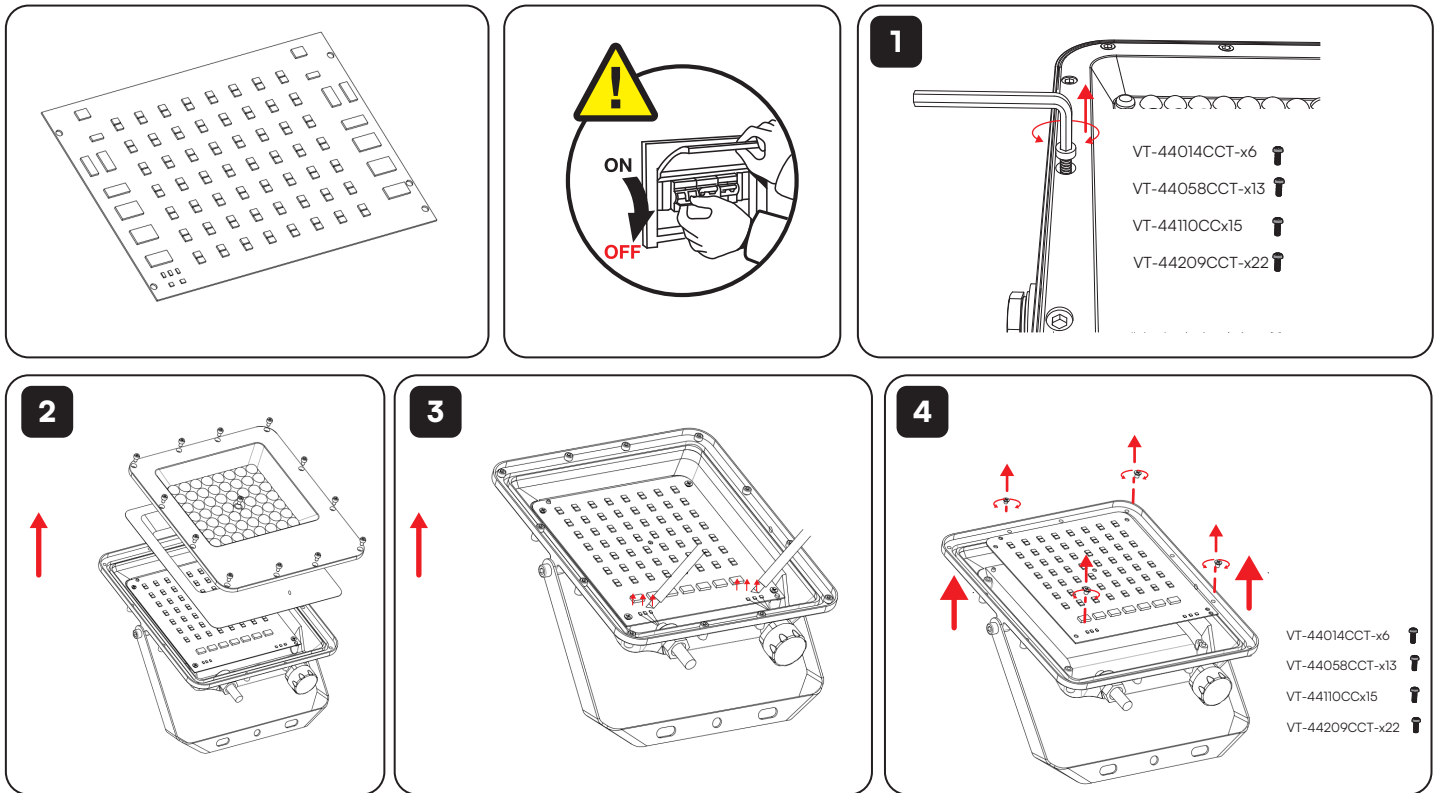

Note: Light source removal will void the warranty

V-TAC WEST EUROPE LTD. IN CASE OF ANY QUERY/ISSUE WITH THE PRODUCT, PLEASE REACH OUT TO US AT:
SUPPORT@V-TAC.EU FOR MORE PRODUCTS RANGE, INQUIRY PLEASE CONTACT OUR DISTRIBUTOR OR NEAREST DEALERS.
V-TAC WEST EUROPE LTD. GROUND FLOOR, 71 LOWER BAGGOT STREET, DUBLIN O2, IRELAND DO2 P593

V-TAC UK LTD. IN CASE OF ANY QUERY/ISSUE WITH THE PRODUCT PLEASE REACH OUT TO US AT
SUPPORT@VTACEXPORTS.COM V-TAC, 5A TUNGSTEN PARK, DOWNS ROAD, WITNEY, OXFORDSHIRE, OX29 0AX



ИНСТРУКЦИЯ ЗА УПОТРЕБА

LED ПРОЖЕКТОР



**IP65
RATING**



ТЕХНИЧЕСКИ ДАННИ

МОДЕЛ	SKU	ВАТ	ПОЛЕЗЕН ЛУМЕН <small>(ШИРИНА КОНИСА)</small>	ЪГЪЛ НА ЛЪЧА	ЖИВОТ [ЧАСА]	DF	CRI	ВХОДНО НАПРЕЖЕНИЕ	РАЗМЕР	Н.Т	МАКСИМАЛНА ВИСОЧИНА НА МОНТАЖ	ПРОЕКТИРАНА ПЛОЩ	ТИП КОРПУС	ИК РЕЙТИНГ
VT-44014CCT	240726	10	730 Lm	90	50 000	>0,9	>80	AC: 220-240V, 50/60Hz	147x33x122	192	3-5	12-34m	Алуминий	IK06
VT-44058CCT	240736	50	4000 Lm	90	50 000	>0,9	>80	AC: 220-240V, 50/60Hz	227x33x182	418	3-5	18,5-50,5m ²	Алуминий	IK06
VT-44110CCT	240716	100	8150 Lm	90	50 000	>0,9	>80	Променлив ток: 220-240 V, 50/60 Hz	297x33x242mm	825 g	3-5m	38-103m	Алуминий	IK06
VT-44209CCT	240706	200	16450 Lm	90	50 000	>0,9	>80	AC: 220-240V, 50/60Hz	410x33x326	1550	3-5	100-200m	Алуминий	IK06

Работната температура за тези продукти е от -20°C до +40°C.

ВЪВЕДЕНИЕ И ГАРАНЦИЯ

Благодарим Ви, че избрахте и закупихте продукт на V-TAC. V-TAC ще Ви обслужва по най-добрия начин. Моля, прочетете внимателно тези инструкции, преди да започнете инсталирането, и запазете това ръководство на удобно място за бъдеща справка. Ако имате други въпроси, моля, свържете се с нашия дистрибутор или местния продавач, от когото сте закупили продукта. Те са обучени и готови да Ви обслужват по най-добрия начин. Гаранцията е валидна за 6 години от датата на покупката. Гаранцията не се отнася за щети, причинени от неправилна инсталация или необичайно износване. Компанията не дава гаранция за щети по повърхности, причинени от неправилно демонтиране и инсталиране на продукта. Продуктите са подходящи за 10-12 часа ежедневна работа. Използването на продукта 24 часа в денонощието ще доведе до анулиране на гаранцията. Гаранцията за този продукт се отнася само за производствени дефекти.

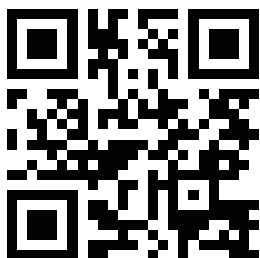

МНОГОЕЗИЧНО РЪКОВОДСТВО QR КОД

Сканирайте QR кода, за да получите достъп до ръководството на различни езици.



FR

Cet appareil,
ses accessoires
et cordons
se recyclent

À DÉPOSER
EN MAGASIN





À DÉPOSER
EN DÉCHÈTERIE



OU

Points de collecte sur www.quefairedemesdechets.fr
Privilégiez la réparation ou le don de votre appareil !

ПРЕДУПРЕЖДЕНИЕ

- Моля, уверете се, че сте изключили захранването, преди да започнете инсталирането.
- Инсталацията трябва да бъде извършена от квалифициран електротехник.
- Светлинният източник, съдържащ се в този осветителен уред, трябва да се сменя само от производителя, негов сервизен представител или подобно квалифицирано лице.
- Външният гъвкав кабел или шнур на този осветителен уред не може да бъде заменен; ако шнурът е повреден, осветителният уред трябва да бъде унищожен.
- Клемната кутия не е включена в комплекта.
- По време на инсталацията трябва да се осигури подходящо заземяване.
- За външна употреба.
- Заменете всеки напукан защитен щит. 
- Минимално разстояние от осветени обекти 1 м. 

ЗАБЕЛЕЖКА

- За да се намали рискът от задушаване, гъвкавото окабеляване, свързано с този осветителен уред, трябва да бъде ефективно закрепено към стената, ако окабеляването е на разстояние, до което може да се достигне с ръка.
- За да се запази IP защитата на продукта, кабелният вход/уплътнението трябва да се монтира от долната страна.

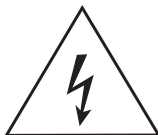

Внимание, опасност от токов удар.



Тази маркировка показва, че този продукт не трябва да се изхвърля заедно с други битови отпадъци.

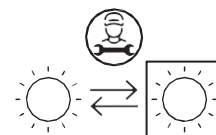

Сменяем източник на светлина от

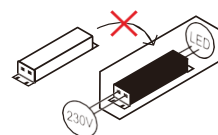

Незаменяемо управляващо

ДИАГРАМА НА МОНТАЖА

1

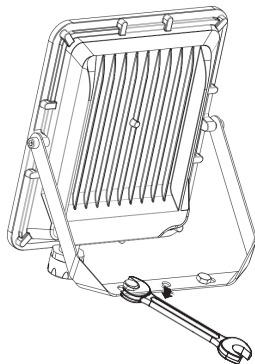

2

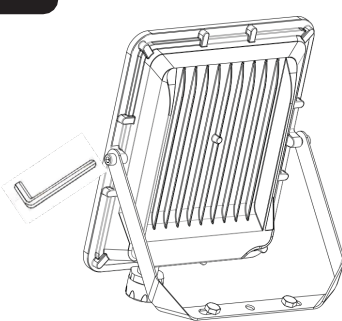

3

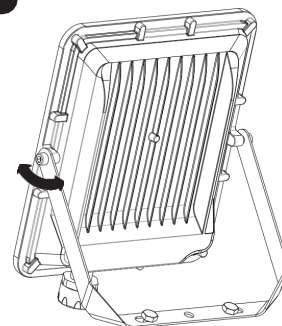

4

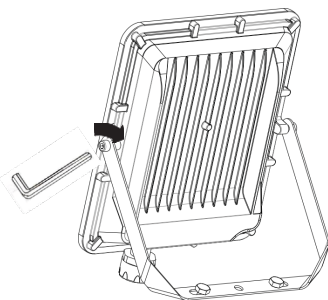

5



СХЕМА НА КАБЕЛИТЕ



ССТ
Превкл

ДЪЛЖИНА НА КАБЕЛА: 120

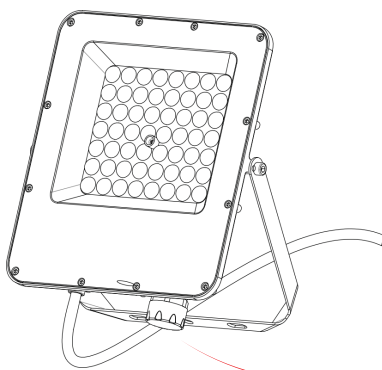
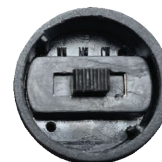
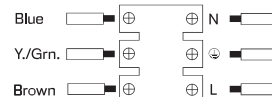
ИНСТРУКЦИИ ЗА МОНТАЖ

Важно: При инсталирането стриктно следвайте стъпките по-долу. Избягвайте да прилагате прекомерна сила върху захранващия кабел. Захранващото свързване и другите външни проводници трябва да са с размери най-малко 3 x 1,0 mm².

- Уверете се, че захранването е изключено, преди да започнете инсталирането.
- Закрепете скобите към желаната повърхност.
- Разхлабете болтовете от двете страни на скобата.
- Нагласете прожектора под желания ъгъл.
- Затегнете болтовете от двете страни на скобата, за да фиксирате позицията.
- Свържете кабелите на прожектора според схемата на свързване.
- Настройте желаната цвятова температура с помощта на превключвателя CCT.
- Включете захранването и тествайте прожектора.

ИНСТРУКЦИИ ЗА ДЕМОНТАЖ

(Само за екипа за надзор на пазара)

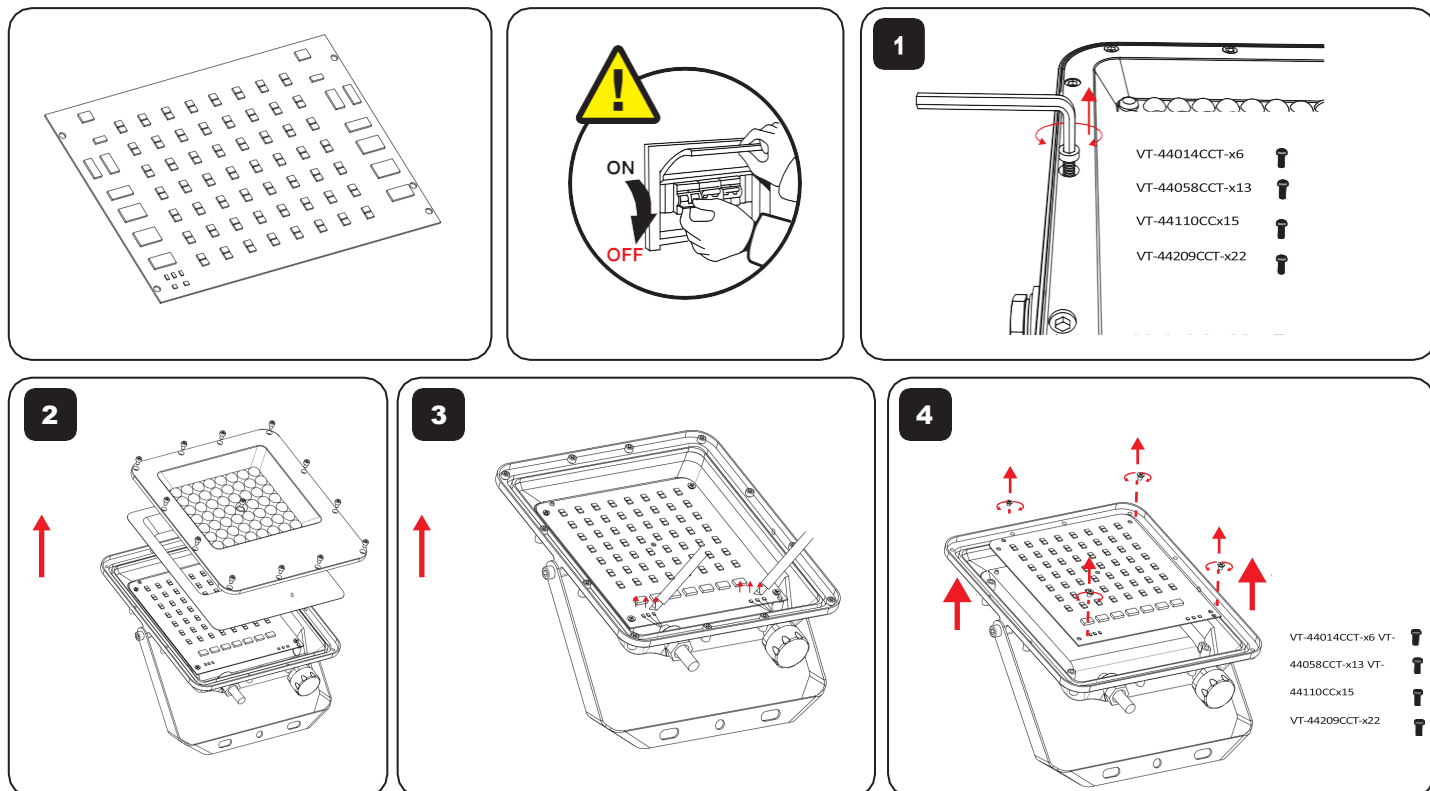

Забележка: Премахването на светлинния източник ще доведе до анулиране на гаранцията.

V-TAC WEST EUROPE LTD. В СЛУЧАЙ НА ВЪПРОСИ/ПРОБЛЕМИ С ПРОДУКТА, МОЛЯ, СВЪРЖЕТЕ СЕ С НАС НА: SUPPORT@V-TAC.EU ЗА ПОВЕЧЕ ПРОДУКТИ, МОЛЯ, СВЪРЖЕТЕ СЕ С НАШИЯ ДИСТРИБУТОР ИЛИ НАЙ-БЛИЗКИЯ ДИЛЪР. V-TAC WEST EUROPE LTD. ПЪРВИ ЕТАЖ, 71 LOWER BAGGOT STREET, ДУБЛИН 02, ИРЛАНДИЯ D02 P593

V-TAC UK LTD. В СЛУЧАЙ НА ВЪПРОСИ/ПРОБЛЕМИ С ПРОДУКТА, МОЛЯ, СВЪРЖЕТЕ СЕ С НАС НА SUPPORT@VTACEXPORTS.COM V-TAC, 5A TUNGSTEN PARK, DOWNS ROAD, WITNEY, OXFORDSHIRE, OX29 0AX



V-TAC

Meaningful Innovation.

UPUTE ZA UPORABU LED REFLEKTOR



IP65
RATING

3 IN 1
CCT

TEHNIČKI PODACI

MODEL	SKU	VATI	KORISTAN LUMEN <small>@ŠIROKI KONUS</small>	ZRAKA KUT	ŽIVOT SPAN [SATI]	DF	CRI	ULAZNI NAPON	DIMENZIJA	SZ	MAX MONTAŽA VISINA	PROJEKTIRANO PODRUČJE	TIJELO TIP	IK OCJENA
VT-44014CCT	240726	10 W	730 lm	90°	50.000	> 0,9	> 80	Imjennina struja: 220-240 V, 50/60 Hz	147x33x122mm	192 g	3-5 m	12-34 m ²	Aluminij	IK06
VT-44058CCT	240736	50 W	4000 lm	90°	50.000	> 0,9	> 80	Imjennina struja: 220-240 V, 50/60 Hz	227x33x182mm	418 g	3-5 m	18,5-50,5 m ²	Aluminij	IK06
VT-44110CCT	240716	100 W	8150 lm	90°	50.000	> 0,9	> 80	Imjennina struja: 220-240 V, 50/60 Hz	297x33x242mm	825 g	3-5 m	38-103 m ²	Aluminij	IK06
VT-44209CCT	240706	200 W	16450 lm	90°	50.000	> 0,9	> 80	Imjennina struja: 220-240 V, 50/60 Hz	410x33x326mm	1550 g	3-5 m	100-200 m ²	Aluminij	IK06

Radni temperaturni raspon za ove artikle je od -20°C do +40°C.

UVOD I JAMSTVO

Hvala vam što ste odabrali i kupili V-TAC proizvod. V-TAC će vam pružiti najbolju moguću uslugu. Molimo vas da pažljivo pročitate ove upute prije početka instalacije i sačuvate ovaj priručnik za buduću upotrebu. Ako imate bilo kakvih dodatnih pitanja, obratite se našem prodavaču ili lokalnom dobavljaču od kojeg ste kupili proizvod. Oni su obučeni i spremni vam pružiti najbolju moguću uslugu. Jamstvo vrijedi 6 godina od datuma kupnje. Jamstvo se ne odnosi na oštećenja uzrokovana nepravilnom instalacijom ili neuobičajenim habanjem. Tvrtka ne daje jamstvo za oštećenja bilo koje površine zbog nepravilnog uklanjanja i instalacije proizvoda. Proizvodi su prikladni za rad od 10-12 sati dnevno. Korištenje proizvoda 24 sata dnevno poništilo bi jamstvo. Jamstvo za ovaj proizvod pokriva samo nedostatke u proizvodnji.



VIŠEJEZIČNO
RUČNI QR KOD

Molimo skenirajte QR kod za pristup priručniku na više jezika.



FR

Cet appareil, ses accessoires et câbles se recyclent

À DÉPOSER EN MAGASIN





À DÉPOSER EN DÉCHÈTERIE



OU

Points de collecte sur www.quefairedemesdechets.fr
Privilégiez la réparation ou le don de votre appareil !

UPOZORENJE

- Prije početka instalacije obavezno isključite napajanje.
- Instalaciju mora izvršiti kvalificirani električar.
- Izvor svjetlosti u ovoj svjetiljci smije zamijeniti samo proizvođač ili njegov servisni agent ili slična kvalificirana osoba.
- Vanjski fleksibilni kabel ili uža ove svjetiljke ne može se zamijeniti; ako je kabel oštećen, svjetiljka će biti uništena.
- Priključni blok nije uključen.
- Tijekom cijele instalacije treba osigurati pravilno uzemljenje.
- Za vanjsku upotrebu.
- Zamijenite svaki napuknuti zaštitni štiti. 
- Minimalna udaljenost od osvijetljenih objekata 1 m. 

BIJJEŠKA

- Kako bi se smanjio rizik od davljenja, fleksibilno ožičenje spojeno na ovu svjetiljku mora biti učinkovito pričvršćeno na zid ako je ožičenje nadohvat ruke.
- Kako bi se održala IP zaštita proizvoda, kabelski ulaz/uvodnica treba biti ugrađena na donjoj strani.

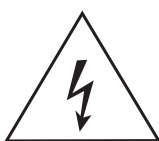

Oprez, opasnost od strujnog udara.



Ova oznaka označava da se ovaj proizvod ne smije odlagati s ostalim kućnim otpadom.



DIJAGRAM UGRADNJE

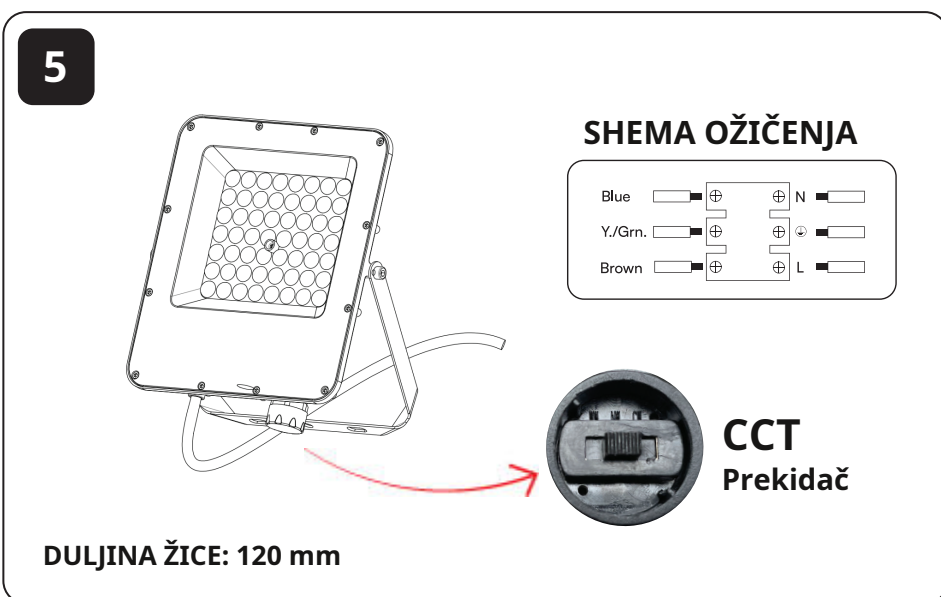
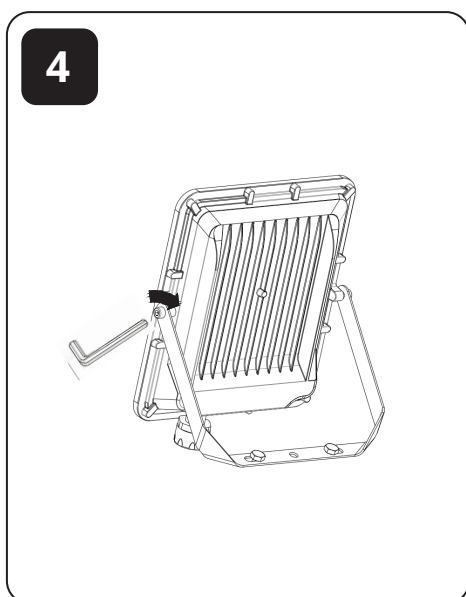
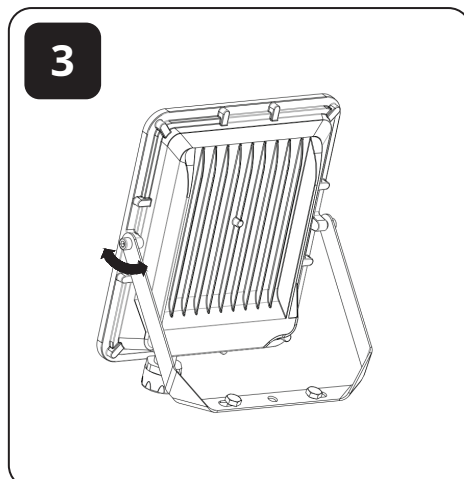
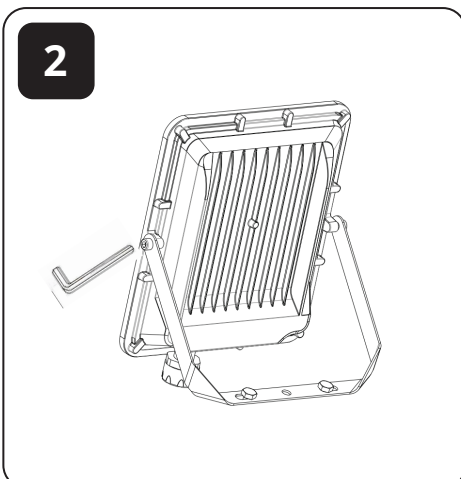
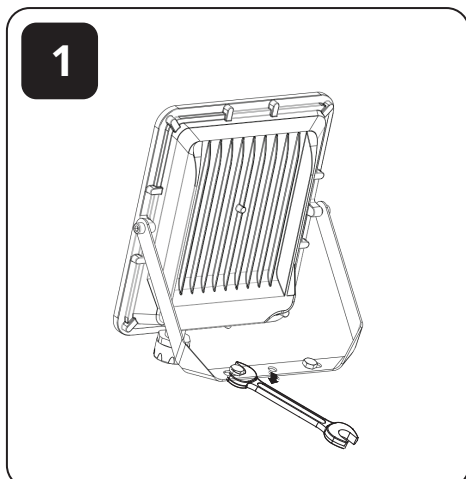

UPUTE ZA UGRADNJU

Važno: Tijekom instalacije strogo slijedite dolje navedene korake. Izbjegavajte primjenu prekomjerne sile na kabel za napajanje. Priključak za napajanje i ostali vanjski vodiči moraju biti presjeka najmanje 3 x 1,0 mm²

- Prije početka instalacije provjerite je li napajanje isključeno.
- Pričvrstite nosače na željenu površinu.
- Otpustite vijke s obje strane nosača.
- Podesite reflektor na željeni kut.
- Zategnite vijke s obje strane nosača kako biste učvrstili položaj.
- Spojite ožičenje reflektora prema dijagramu ožičenja.
- Podesite željenu temperaturu boje pomoću CCT prekidača.
- Uključite napajanje i testirajte reflektor.

UPUTE ZA DEMONTAŽU

(Samo za tim za nadzor tržišta)

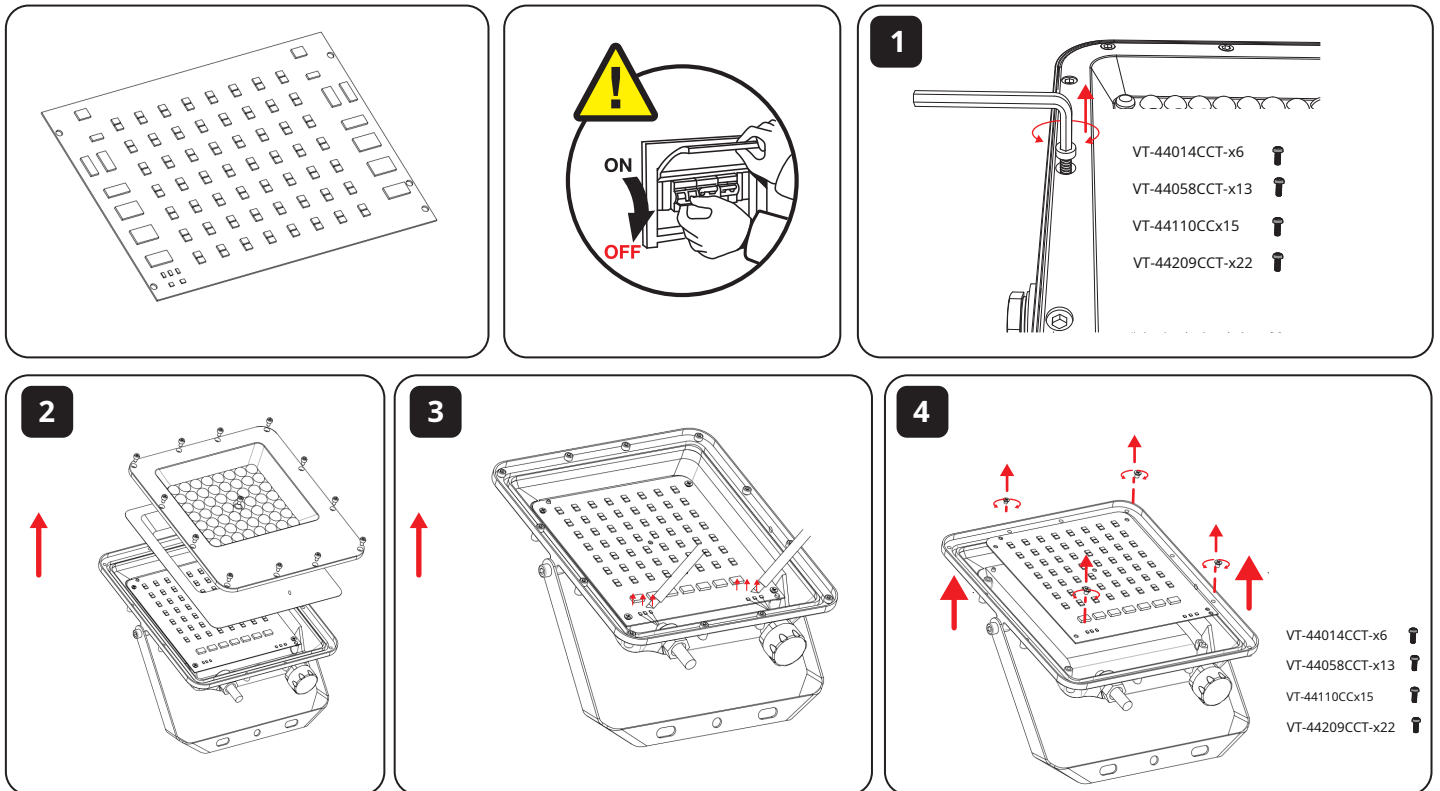

Napomena: Uklanjanje izvora svjetlosti poništava jamstvo

V-TAC WEST EUROPE LTD. U SLUČAJU BILO KAKVOG UPITA/PROBLEMA S PROIZVODOM, MOLIMO VAS DA NAM SE OBRAĆATE NA: SUPPORT@V-TAC.EU ZA VIŠE PROIZVODA ILI UPITE MOLIMO VAS DA KONTAKTIRATE NAŠEG DISTRIBUTERA ILI NAJBLIŽE TRGOVCE.
V-TAC WEST EUROPE LTD. PRIZEMLJE, 71 LOWER BAGGOT STREET, DUBLIN 02, IRSKA DO2 P593

V-TAC UK d.o.o. U SLUČAJU BILO KAKVIH UPITA/PROBLEMA S PROIZVODOM, MOLIMO VAS DA NAM SE OBRAĆATE NA SUPPORT@VTACEXPORTS.COM V-TAC, 5A TUNGSTEN PARK, DOWNS ROAD, WITNEY, OXFORDSHIRE, OX29 0AX



V-TAC

Meaningful Innovation.

NÁVOD K POUŽITÍ LED PROJEKTOROVÉ SVÍTIDLO



IP65
RATING

3 IN 1
CCT

TECHNICKÉ ÚDAJE

MODEL	SKU	W	POUŽITÉ LNÝ LUMEN @ŠIROKÝ KÚŽEL	ÚHEL SVĚTEL NĚHO KÚŽELE	ŽIVOTNOST T [HODINY]	DF	CRI	VSTUPNÍ NAPĚTÍ	ROZMĚRY	N.W	MAXIMÁLNÍ MONTÁŽNÍ VÝŠKA	PŘEDPOKLÁDANÁ PLOCHA	TYP TĚLA	IK HODNOCENÍ
VT-44014CCT	240726	10	730 Lm	90	50 000	>0,9	>80	Střídavý proud: 220-240 V, 50/60 Hz	147 x 33 x 122 mm	192	3-5 m	12-34 m ²	Hliník	IK06
VT-44058CCT	240736	50 W	4000 Lm	90	50 000	>0,9	>80	Střídavý proud: 220-240 V, 50/60 Hz	227 x 33 x 182 mm	418 g	3-5 m	18,5-50,5 m ²	Hliník	IK06
VT-44110CCT	240716	100 W	8150 Lm	90	50 000	>0,9	>80	Střídavý proud: 220-240 V, 50/60 Hz	297 x 33 x 242 mm	825 g	3-5 m	38-103 m ²	Hliník	IK06
VT-44209CCT	240706	200 W	16450 Lm	90	50 000	>0,9	>80	Střídavý proud: 220-240 V, 50/60 Hz	410 x 33 x 326 mm	1550 g	3-5 m	100-200 m ²	Hliník	IK06

Provozní teplota těchto výrobků je -20 °C až +40 °C.

ÚVOD A ZÁRUKA

Děkujeme, že jste si vybrali a zakoupili produkt V-TAC. V-TAC vám poskytne ty nejlepší služby. Před zahájením instalace si prosím pečlivě přečtěte tyto pokyny a uchovejte tento návod pro budoucí použití. Máte-li jakékoli další dotazy, obraťte se na našeho prodejce nebo místního dodavatele, od kterého jste produkt zakoupili. Jsou proškoleni a připraveni vám poskytnout ty nejlepší služby. Záruka platí po dobu 6 let od data zakoupení. Záruka se nevztahuje na poškození způsobené nesprávnou instalací nebo abnormálním opotřebením. Společnost neposkytuje žádnou záruku na poškození povrchu v důsledku nesprávného demontování a instalace produktu. Produkty jsou vhodné pro 10-12 hodin denního provozu. Používání produktu 24 hodin denně by vedlo ke ztrátě záruky. Na tento produkt se vztahuje záruka pouze na výrobní vady.

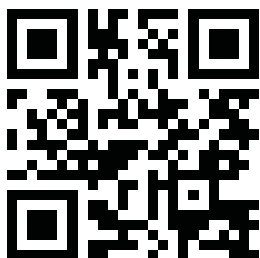

VÍCEJAZYČNÝ NÁVOD QR KÓD

Naskenujte QR kód a získáte přístup k návodu v několika jazycích.



FR

Cet appareil, ses accessoires et câbles se recyclent

À DÉPOSER EN MAGASIN





À DÉPOSER EN DÉCHÈTERIE



OU

Points de collecte sur www.quefairedemesdechets.fr
Privilégiez la réparation ou le don de votre appareil !

UPOZORNĚNÍ

- Před zahájením instalace se ujistěte, že je zařízení odpojeno od napájení.
- Instalace musí být provedena kvalifikovaným elektrikářem.
- Světelný zdroj obsažený v tomto svítidle smí vyměnit pouze výrobce, jeho servisní zástupce nebo podobně kvalifikovaná osoba.
- Externí ohebný kabel nebo šňůra tohoto svítidla nelze vyměnit; pokud je šňůra poškozená, svítidlo musí být zlikvidováno.
- Svorkovnice není součástí dodávky.
- Během celé instalace je třeba zajistit správné uzemnění.
- Pro venkovní použití.
- Vyměňte všechny prasklé ochranné kryty. 
- Minimální vzdálenost od osvětlených předmětů 1 m. 

POZNÁMKA

- Aby se snížilo riziko uškrcení, musí být flexibilní kabeláž připojená k tomuto svítidlu účinně připevněna ke zdi, pokud je kabeláž v dosahu ruky.
- Aby byla zachována ochrana IP produktu, kabelová průchodka/uzávěr by měly být instalovány na spodní straně.



Pozor, nebezpečí úrazu elektrickým proudem.



Toto označení znamená, že tento produkt nesmí být likvidován spolu s ostatním domácím odpadem.

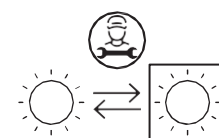

Vyměnitelný světelný zdroj pouze odborníkem

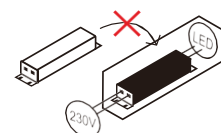

Nenahraditelné ovládací

INSTALAČNÍ SCHÉMA

1

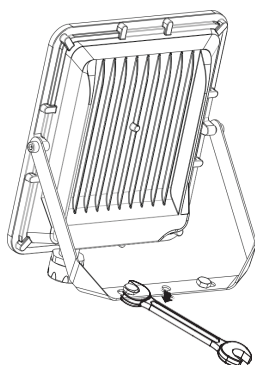

2

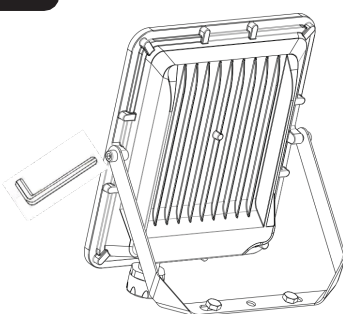

3

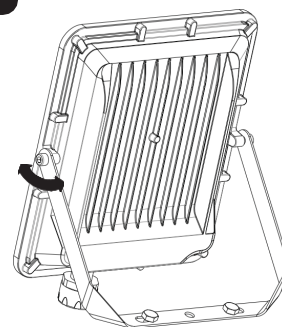

4

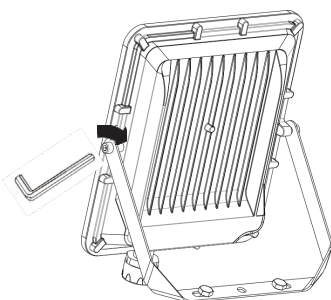

5



SCHÉMA ZAPOJENÍ



CCT
Spínač

DÉLKA KABELU: 120

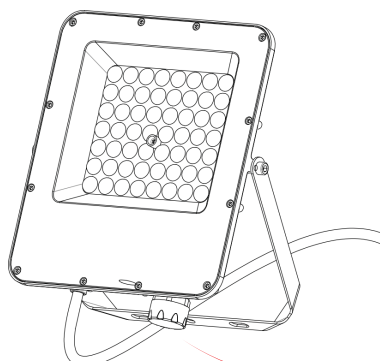
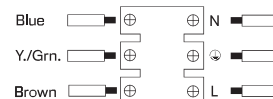
NÁVOD K INSTALACI

Důležité: Při instalaci přísně dodržujte níže uvedené kroky. Vyvarujte se nadměrného namáhání napájecího kabelu. Napájecí připojení a ostatní vnější vodiče musí mít průřez minimálně 3 x 1,0 mm².

- Před zahájením instalace se ujistěte, že je zařízení vypnuté.
- Připevněte držáky k požadovanému povrchu.
- Povolte šrouby na obou stranách držáku.
- Nastavte reflektor do požadovaného úhlu.
- Utáhněte šrouby na obou stranách držáku, aby se zajistila jeho poloha.
- Připojte kabeláž reflektoru podle schématu zapojení.
- Nastavte požadovanou teplotu barev pomocí přepínače CCT.
- Zapněte napájení a vyzkoušejte reflektor.

POKYNY K DEMONTÁŽI

(Pouze pro tým pro dohled nad trhem)

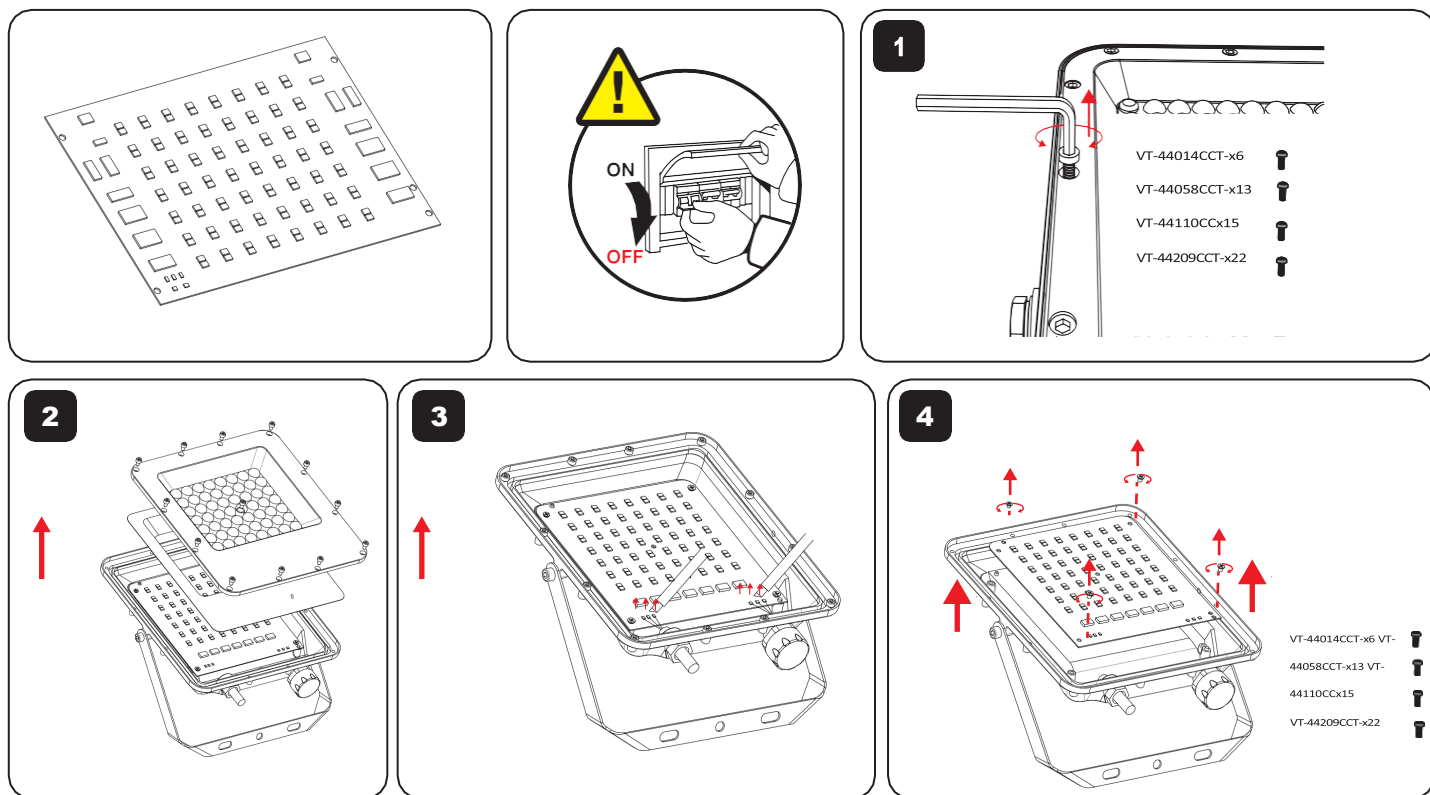

Poznámka: Odstranění světelného zdroje vede ke ztrátě záruky.

V-TAC WEST EUROPE LTD. V PŘÍPADĚ JAKÝCHKOLI DOTAZŮ/PROBLÉMŮ S PRODUKTEM NÁS KONTAKTUJTE NA ADRESE: SUPPORT@V-TAC.EU PRO VÍCE INFORMACÍ O PRODUKTOVÉ ŘADĚ SE OBRATTE NA NAŠEHO DISTRIBUTORA NEBO NEJBLIŽŠÍHO PRODEJCE. V-TAC WEST EUROPE LTD. GROUND FLOOR, 71 LOWER BAGGOT STREET, DUBLIN 02, IRSKO DO2 P593

V-TAC UK LTD. V PŘÍPADĚ JAKÝCHKOLI DOTAZŮ/PROBLÉMŮ S PRODUKTEM NÁS KONTAKTUJTE NA A D R E S E SUPPORT@VTACEXPORTS.COM V-TAC, 5A TUNGSTEN PARK, DOWNS ROAD, WITNEY, OXFORDSHIRE, OX29 0AX



V-TAC

Meaningful Innovation.

MANUEL D'INSTRUCTIONS

PROJECTEUR À LED



IP65
RATING



DONNÉES TECHNIQUES

MODÈLE	SKU	WATTS	LUMENS UTILES (@3000K LARGE)	ANGLE DU FAISCEAU	DURÉE DE VIE [HEURES]	DF	IR	TENSION D'ENTRÉE	DIMENSIONS	N.W	HAUTEUR MAXIMALE DE MONTAGE	SURFACE PROJETÉE	TYPE DE CORPS	INDIC E IK
VT-44014CCT	240726	10	730 Lm	90	50 000	>0,9	>80	CA : 220-240 V, 50/60 Hz	147 x 33 x 122 mm	192 g	3-5 m	12-34 m ²	Aluminium	IK06
VT-44058CCT	240736	50 W	4000 Lm	90	50 000	>0,9	>80	CA : 220-240 V, 50/60 Hz	227 x 33 x 182 mm	418 g	3-5 m	18,5-50,5 m ²	Aluminium	IK06
VT-44110CCT	240716	100 W	8150 Lm	90	50 000	>0,9	>80	CA : 220-240 V, 50/60 Hz	297 x 33 x 242 mm	825 g	3-5 m	38-103 m ²	Aluminium	IK06
VT-44209CCT	240706	200 W	16450 Lm	90	50 000	>0,9	>80	CA : 220-240 V, 50/60 Hz	410 x 33 x 326 mm	1 550 g	3-5 m	100-200 m ²	Aluminium	IK06

La plage de température de fonctionnement de ces articles est comprise entre -20 °C et +40 °C.

INTRODUCTION ET GARANTIE

Merci d'avoir choisi et acheté un produit V-TAC. V-TAC vous offrira le meilleur service possible. Veuillez lire attentivement ces instructions avant de commencer l'installation et conservez ce manuel à portée de main pour référence ultérieure. Si vous avez d'autres questions, veuillez contacter notre revendeur ou le fournisseur local auprès duquel vous avez acheté le produit. Ils sont formés et prêts à vous offrir le meilleur service possible. La garantie est valable pendant 6 ans à compter de la date d'achat. La garantie ne s'applique pas aux dommages causés par une installation incorrecte ou une usure anormale. La société n'offre aucune garantie contre les dommages causés à toute surface en raison d'un démontage et d'une installation incorrects du produit. Les produits sont adaptés à une utilisation quotidienne de 10 à 12 heures. L'utilisation du produit 24 heures sur 24 annulerait la garantie. Ce produit est garanti uniquement contre les défauts de fabrication.



MANUEL MULTILINGUE CODE QR

Veuillez scanner le code QR pour accéder au manuel en plusieurs langues.



FR

Cet appareil, ses accessoires et cordons se recyclent

À DÉPOSER EN MAGASIN

À DÉPOSER EN DÉCHÈTERIE





OU



Points de collecte sur www.quefairedemesdechets.fr
Privilégiez la réparation ou le don de votre appareil !

EN CAS DE QUESTION OU DE PROBLÈME CONCERNANT LE PRODUIT, VEUILLEZ NOUS CONTACTER À L'ADRESSE SUIVANTE :
SUPPORT@V-TAC.EU POUR CONNAÎTRE LA GAMME COMPLÈTE DE PRODUITS, VEUILLEZ CONTACTER NOTRE DISTRIBUTEUR OU
LE REVENDEUR LE PLUS PROCHE. V-TAC EUROPE LTD. BULGARIE, PLOVDIV 4000, BUL.L.KARAVELOW 9B

AVERTISSEMENT

- Veuillez à couper l'alimentation électrique avant de commencer l'installation.
- L'installation doit être effectuée par un électricien qualifié.
- La source lumineuse contenue dans ce luminaire ne doit être remplacée que par le fabricant, son agent de service ou une personne qualifiée similaire.
- Le câble ou cordon flexible externe de ce luminaire ne peut pas être remplacé ; si le cordon est endommagé, le luminaire doit être détruit.
- Bornier non inclus.
- Une mise à la terre adéquate doit être assurée tout au long de l'installation.
- Pour usage extérieur.
- Remplacer tout écran de protection fissuré. 
- Distance minimale par rapport aux objets éclairés : 1 m. 

REMARQUE

- Afin de réduire le risque d'étranglement, le câblage flexible connecté à ce luminaire doit être solidement fixé au mur si le câblage est à portée de main.
- Afin de préserver la protection IP du produit, le presse-étoupe doit être installé sur la face inférieure.

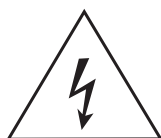
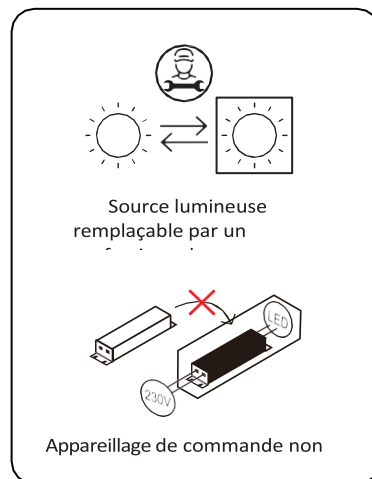

Attention, risque d'électrocution.



Ce marquage indique que ce produit ne doit pas être jeté avec les autres déchets ménagers.

SCHÉMA D'INSTALLATION

1

2

3

4

5

SCHÉMA DE

Blue	⊕	⊕	N
Y./Grn.	⊕	⊕	⊖
Brown	⊕	⊕	L

CCT Interru

LONGUEUR DU FIL : 120

INSTRUCTIONS D'INSTALLATION

Important : suivez scrupuleusement les étapes ci-dessous lors de l'installation. Évitez d'exercer une force excessive sur le câble d'alimentation. Le raccordement d'alimentation et les autres conducteurs de câblage externes doivent avoir une section minimale de 3 x 1,0 mm².

- Assurez-vous que l'alimentation électrique est coupée avant de commencer l'installation.
- Fixez les supports à la surface souhaitée.
- Desserrez les boulons des deux côtés du support.
- Réglez le projecteur à l'angle souhaité.
- Serrez les boulons des deux côtés du support pour fixer la position.
- Connectez le câblage du projecteur conformément au schéma de câblage.
- Réglez la température de couleur souhaitée à l'aide du commutateur CCT.
- Mettez l'appareil sous tension et testez le projecteur.

INSTRUCTIONS DE DÉMONTAGE

(Réservé à l'équipe de surveillance du marché)

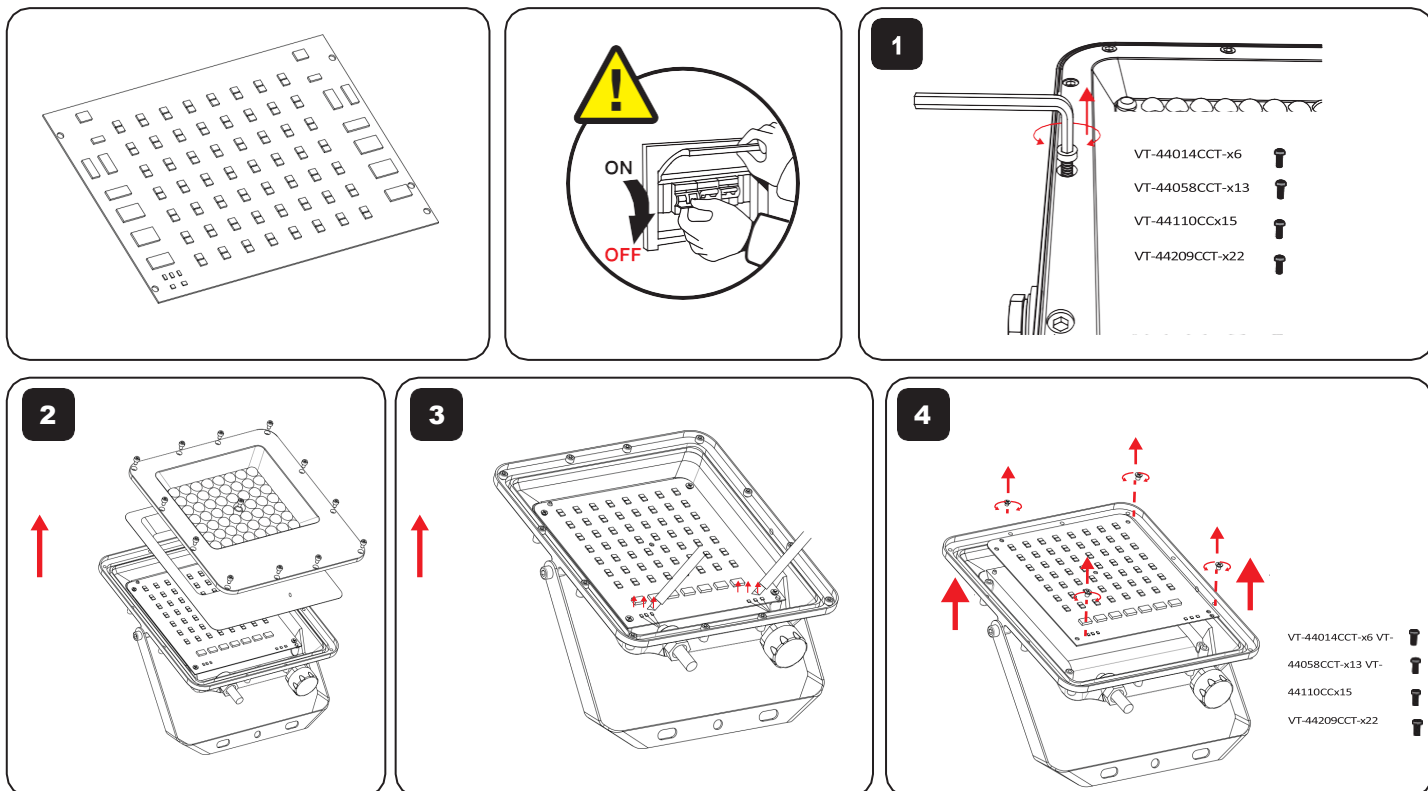

Remarque : le retrait de la source lumineuse annulera la garantie.

V-TAC WEST EUROPE LTD. EN CAS DE QUESTION OU DE PROBLÈME CONCERNANT LE PRODUIT, VEUILLEZ NOUS CONTACTER À L'ADRESSE SUIVANTE : SUPPORT@V-TAC.EU POUR CONNAÎTRE LA GAMME COMPLÈTE DE PRODUITS, VEUILLEZ CONTACTER NOTRE DISTRIBUTEUR OU LE REVENDEUR LE PLUS PROCHE. V-TAC WEST EUROPE LTD. REZ-DE-CHAUSSÉE, 71 LOWER BAGGOT STREET, DUBLIN 02, IRLANDE D02 P593

V-TAC UK LTD. EN CAS DE QUESTION/PROBLÈME CONCERNANT LE PRODUIT, VEUILLEZ NOUS CONTACTER À L'ADRESSE SUIVANTE : SUPPORT@VTACEXPORTS.COM V-TAC, 5A TUNGSTEN PARK, DOWNS ROAD, WITNEY, OXFORDSHIRE, OX29 0AX



V-TAC

Meaningful Innovation.

BEDIENUNGSANLEITUNG LED-FLUTLICHT



IP65
RATING

3 IN 1
CCT

TECHNICAL DATA

MODELL	SKU	WATT	NUTZ LUMEN @WIDE CONE	STRAHL WINKEL	LEBENS DAUER [STUNDEN]	DF	CRI	EINGANGSS PANNUNG	DIMENSION	N.W	MAXIMALE MON TAGEHOHE	PROJEKTIERTE FLÄCHE	KÖRPER TYP	IK BEWE RTUNG
VT-44014CCT	240726	10W	730 Lm	90°	50.000	>0.9	>80	AC: 220-240V, 50/60Hz	147x33x122mm	192g	3-5m	12-34m ²	Aluminium	IK06
VT-44058CCT	240736	50W	4000 Lm	90°	50.000	>0.9	>80	AC: 220-240V, 50/60Hz	227x33x182mm	418g	3-5m	18.5-50.5m ²	Aluminium	IK06
VT-44110CCT	240716	100W	8150 Lm	90°	50.000	>0.9	>80	AC: 220-240V, 50/60Hz	297x33x242mm	825g	3-5m	38-103m ²	Aluminium	IK06
VT-44209CCT	240706	200W	16450 Lm	90°	50.000	>0.9	>80	AC: 220-240V, 50/60Hz	410x33x326mm	1550g	3-5m	100-200m ²	Aluminium	IK06

Der Betriebstemperaturbereich für diese Artikel liegt zwischen -20 °C und +40 °C.

EINLEITUNG & GARANTIE

Vielen Dank, dass Sie sich für ein Produkt von V-TAC entschieden haben. V-TAC wird Ihnen den bestmöglichen Service bieten. Bitte lesen Sie diese Anleitung vor Beginn der Installation sorgfältig durch und bewahren Sie sie zum späteren Nachschlagen griffbereit auf. Bei weiteren Fragen wenden Sie sich bitte an unseren Händler oder den lokalen Anbieter, bei dem Sie das Produkt gekauft haben. Diese sind geschult und stehen Ihnen gerne zur Verfügung. Die Garantie gilt für 6 Jahre ab Kaufdatum. Die Garantie gilt nicht für Schäden, die durch unsachgemäße Installation oder abnormalen Verschleiß verursacht wurden. Das Unternehmen übernimmt keine Garantie für Schäden an Oberflächen, die durch unsachgemäße Entfernung und Installation des Produkts entstanden sind. Die Produkte sind für einen täglichen Betrieb von 10-12 Stunden geeignet. Bei einer Nutzung des Produkts für 24 Stunden am Tag erlischt die Garantie. Diese Garantie gilt nur für Herstellungsfehler.



FR

Cet appareil, ses accessoires et cordons se recyclent

À DÉPOSER EN MAGASIN



À DÉPOSER EN DÉCHÈTERIE





OU

Points de collecte sur www.quefairedemesdechets.fr
Privilégiez la réparation ou le don de votre appareil !

BEI FRAGEN ODER PROBLEMEN MIT DEM PRODUKT WENDEN SIE SICH BITTE AN: SUPPORT@V-TAC.EU FÜR WEITERE PRODUKTINFORMATIONEN WENDEN SIE SICH BITTE AN UNSEREN VERTRIEBSPARTNER ODER DEN NÄCHSTGELEGENEN HÄNDLER. V-TAC EUROPE LTD. BULGARIEN, PLOVDIV 4000, BUL.L.KARAVELOW 9B

WARNING

- Bitte schalten Sie vor Beginn der Installation unbedingt den Strom ab.
- Die Installation muss von einem qualifizierten Elektriker durchgeführt werden.
- Die in dieser Leuchte enthaltene Lichtquelle darf nur vom Hersteller oder seinem Kundendienst oder einer ähnlich qualifizierten Person ausgetauscht werden.
- Das externe flexible Kabel oder die Schnur dieser Leuchte kann nicht ausgetauscht werden; wenn die Schnur beschädigt ist, muss die Leuchte entsorgt werden.
- Klemmenblock nicht im Lieferumfang enthalten.
- Während der gesamten Installation muss für eine ordnungsgemäße Erdung gesorgt werden.
- Für den Außenbereich.
- Ersetzen Sie alle rissigen Schutzabdeckungen. 
- Mindestabstand zu beleuchteten Objekten 1 m. 

HINWEIS

- Um die Strangulierungsgefahr zu verringern, muss die an diese Leuchte angeschlossene flexible Verkabelung wirksam an der Wand befestigt werden, wenn sich die Verkabelung in Reichweite befindet.
- Um die IP-Schutzart des Produkts aufrechtzuerhalten, sollte die Kabeleinführung/Ver-schraubung an der Unterseite installiert werden.

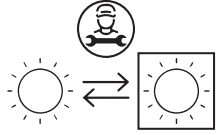

Replaceable light source by a professional

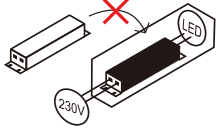

Non-replaceable control gear



Vorsicht, Gefahr eines Stromschlags.



Diese Kennzeichnung weist darauf hin, dass dieses Produkt nicht mit dem Hausmüll entsorgt werden darf.

INSTALLATIONSDIAGRAMM

1

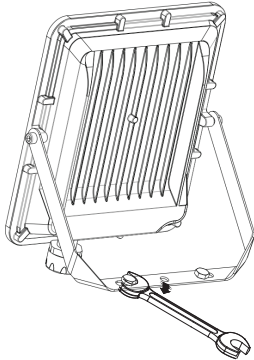

2

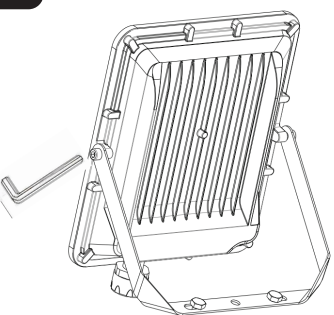

3

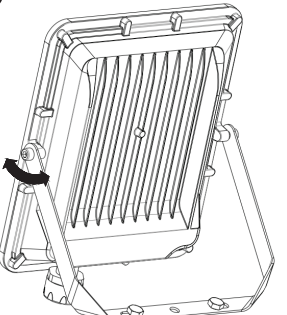

4

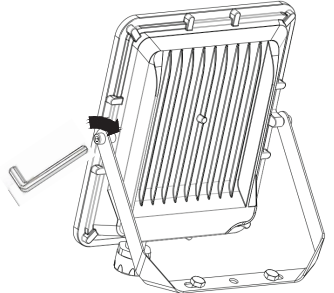

5

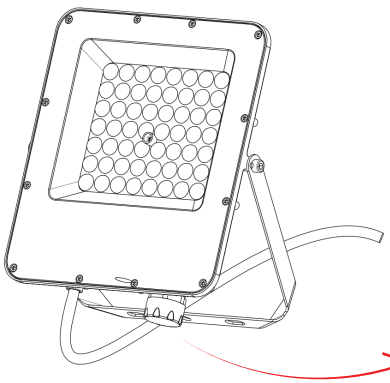

DRAHT LÄNGE: 120 mm

VERKABELUNGSPLAN

Blue	⊕	⊕	N	⊖
Y./Grn.	⊕	⊕	⊖	⊖
Brown	⊕	⊕	L	⊖



CCT
Schalter

INSTALLATIONSANLEITUNG

Wichtig: Befolgen Sie bei der Installation unbedingt die folgenden Schritte. Üben Sie keine übermäßige Kraft auf das Stromkabel aus. Der Versorgungsanschluss und andere externe Verdrahtungsleiter müssen mindestens 3 x 1,0 mm² groß sein.

- Stellen Sie sicher, dass die Stromversorgung ausgeschaltet ist, bevor Sie mit der Installation beginnen.
- Befestigen Sie die Halterungen an der gewünschten Oberfläche.
- Lösen Sie die Schrauben auf beiden Seiten der Halterung.
- Stellen Sie den Scheinwerfer auf den gewünschten Winkel ein.
- Ziehen Sie die Schrauben auf beiden Seiten der Halterung fest, um die Position zu sichern.
- Schließen Sie die Verkabelung des Scheinwerfers gemäß dem Schaltplan an.
- Stellen Sie die gewünschte Farbtemperatur mit dem CCT-Schalter ein.
- Schalten Sie die Stromversorgung ein und testen Sie den Scheinwerfer.

DEMONTAGEANLEITUNG

(Nur für das Marktüberwachungsteam)

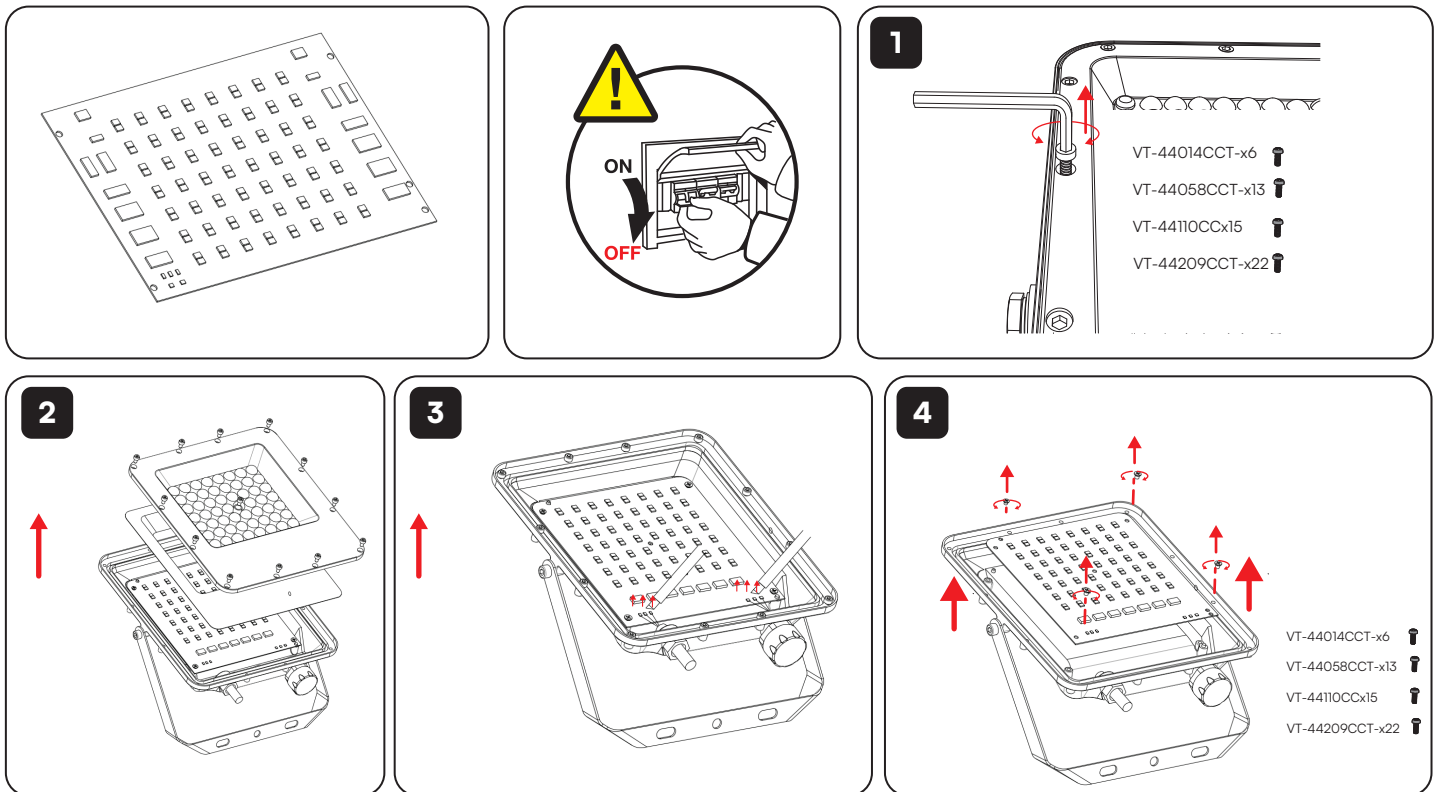

Hinweis: Durch das Entfernen der Lichtquelle erlischt die Garantie.

V-TAC WEST EUROPE LTD. BEI FRAGEN/PROBLEMEN MIT DEM PRODUKT WENDEN SIE SICH BITTE AN: SUPPORT@V-TAC.EU
FÜR WEITERE PRODUKTE UND ANFRAGEN WENDEN SIE SICH BITTE AN UNSEREN VERTRIEBSPARTNER ODER DEN NÄCHSTGELEGENEN HÄNDLER. V-TAC WEST EUROPE LTD. GROUND FLOOR, 71 LOWER BAGGOT STREET, DUBLIN O2, IRLAND DO2 P593

V-TAC UK LTD. BEI FRAGEN/PROBLEMEN MIT DEM PRODUKT WENDEN SIE SICH BITTE AN
SUPPORT@VTACEXPORTS.COM V-TAC, 5A TUNGSTEN PARK, DOWNS ROAD, WITNEY, OXFORDSHIRE, OX29 0AX



ΕΓΧΕΙΡΙΔΙΟ ΟΔΗΓΙΩΝ

LED FLOOD LIGHT



IP65
RATING



ΤΕΧΝΙΚΑ ΣΤΟΙΧΕΙΑ

ΜΟΝΤΕΛΟ	SKU	W	ΧΡΗΣΙΜΟΣ ΛΟΥΜΕΝ (BEYOND KCDICE)	ΓΩΝΙΑ ΔΟΚΗΣ	ΔΙΑΡΚΕΙΑ ΖΩΗΣ [ΩΡΕΣ]	DF	CRI	ΤΑΣΗ ΕΙΣΟΔΟΥ	ΔΙΑΣΤΑΣΕΙΣ	N.W	Μέγιστο ύψος τοποθέτησης	ΠΡΟΒΛΕΠΟΜΕΝ Η ΕΠΙΦΑΝΕΙΑ	ΤΥΠΟΣ ΣΩΜΑΤΟΣ	ΒΑΘΜ ΟΛΟΓΙΑ IK
VT-44014CCT	240726	10W	730 Lm	90	50.000	>0,9	>80	AC: 220-240V, 50/60Hz	147x33x122mm	192	3-5	12-34m ²	Αλουμίνιο	IK06
VT-44058CCT	240736	50W	4000 Lm	90	50.000	>0,9	>80	AC: 220-240V, 50/60Hz	227x33x182mm	418g	3-5	18,5-50,5 m ²	Αλουμίνιο	IK06
VT-44110CCT	240716	100W	8150 Lm	90	50.000	>0,9	>80	AC: 220-240V, 50/60Hz	297x33x242mm	825g	3-5m	38-103m ²	Αλουμίνιο	IK06
VT-44209CCT	240706	200W	16450 Lm	90	50.000	>0,9	>80	AC: 220-240V, 50/60Hz	410x33x326mm	1550g	3-5	100-200m ²	Αλουμίνιο	IK06

Το εύρος θερμοκρασίας λειτουργίας για αυτά τα είδη είναι από -20°C έως +40°C.

ΕΙΣΑΓΩΓΗ & ΕΓΓΥΗΣΗ

Σας ευχαριστούμε που επιλέξατε και αγοράσατε ένα προϊόν V-TAC. Η V-TAC θα σας προσφέρει την καλύτερη εξυπηρέτηση. Διαβάστε προσεκτικά αυτές τις οδηγίες πριν ξεκινήσετε την εγκατάσταση και φυλάξτε αυτό το εγχειρίδιο σε προσιτό μέρος για μελλοντική αναφορά. Εάν έχετε οποιαδήποτε άλλη ερώτηση, επικοινωνήστε με τον αντιπρόσωπο ή τον τοπικό προμηθευτή από τον οποίο αγοράσατε το προϊόν. Είναι εκπαιδευμένοι και έτοιμοι να σας εξυπηρετήσουν με τον καλύτερο δυνατό τρόπο. Η εγγύηση ισχύει για 6 χρόνια από την ημερομηνία αγοράς. Η εγγύηση δεν ισχύει για ζημιές που προκλήθηκαν από λανθασμένη εγκατάσταση ή ανώμαλη φθορά. Η εταιρεία δεν παρέχει εγγύηση για ζημιές σε οποιαδήποτε επιφάνεια λόγω λανθασμένης αφαίρεσης και εγκατάστασης του προϊόντος. Τα προϊόντα είναι κατάλληλα για 10-12 ώρες καθημερινής λειτουργίας. Η χρήση του προϊόντος για 24 ώρες την ημέρα θα ακυρώσει την εγγύηση. Αυτό το προϊόν καλύπτεται από εγγύηση μόνο για κατασκευαστικά ελαττώματα.

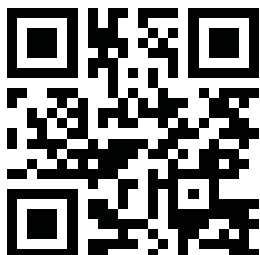

ΠΟΛΥΓΛΩΣΣΟ ΕΓΧΕΙΡΙΔΙΟ QR CODE

Σαρώστε τον κωδικό QR για να αποκτήσετε πρόσβαση στο εγχειρίδιο σε πολλές γλώσσες.



FR

Cet appareil, ses accessoires et cordons se recyclent

À DÉPOSER EN MAGASIN

À DÉPOSER EN DÉCHÈTERIE



OU



Points de collecte sur www.quefairedemesdechets.fr
Privilégiez la réparation ou le don de votre appareil !

ΠΡΟΕΙΔΟΠΟΙΗΣΗ

- Βεβαιωθείτε ότι έχετε απενεργοποιήσει την τροφοδοσία πριν ξεκινήσετε την εγκατάσταση.
- Η εγκατάσταση πρέπει να πραγματοποιείται από εξειδικευμένο ηλεκτρολόγο.
- Η πηγή φωτός που περιέχεται σε αυτό το φωτιστικό πρέπει να αντικαθίσταται μόνο από τον κατασκευαστή ή τον αντιπρόσωπό του ή από άλλο εξειδικευμένο άτομο.
- Το εξωτερικό εύκαμπτο καλώδιο ή το κορδόνι αυτού του φωτιστικού δεν μπορεί να αντικατασταθεί. Εάν το κορδόνι είναι κατεστραμμένο, το φωτιστικό πρέπει να καταστραφεί.
- Δεν περιλαμβάνεται τερματικός πίνακας.
- Κατά την εγκατάσταση πρέπει να εξασφαλίζεται η σωστή γείωση.
- Για χρήση σε εξωτερικούς χώρους.
- Αντικαταστήστε οποιοδήποτε προστατευτικό κάλυμμα που έχει ραγίσει.
- Ελάχιστη απόσταση από φωτεινά αντικείμενα 1 m. 

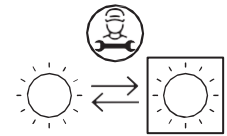

Αντικαταστάσιμη πηγή φωτός από επαγγελματία

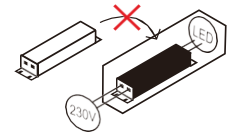

Μη αντικαταστάσιμος

ΣΗΜΕΙΩΣΗ

- Για να μειωθεί ο κίνδυνος στραγγαλισμού, η εύκαμπτη καλωδίωση που συνδέεται με αυτό το φωτιστικό πρέπει να στερεώνεται αποτελεσματικά στον τοίχο, εάν η καλωδίωση βρίσκεται σε απόσταση που μπορεί να φτάσει το χέρι.
- Για να διατηρηθεί η προστασία IP του προϊόντος, η είσοδος καλωδίου/ο δακτύλιος πρέπει να εγκατασταθεί στην κάτω πλευρά.

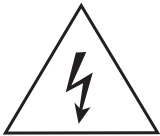

Προσοχή, κίνδυνος ηλεκτροπληξίας.



Αυτή η σήμανση υποδεικνύει ότι το προϊόν αυτό δεν πρέπει να απορρίπτεται μαζί με άλλα οικιακά απορρίμματα.

ΔΙΑΓΡΑΜΜΑ ΕΓΚΑΤΑΣΤΑΣΗΣ

1

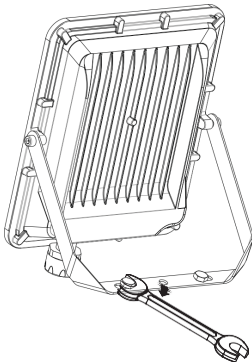

2

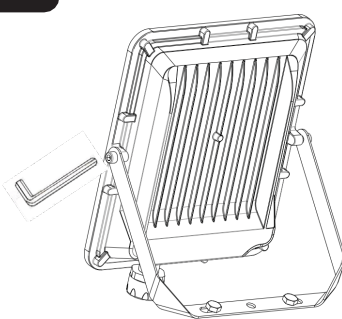

3

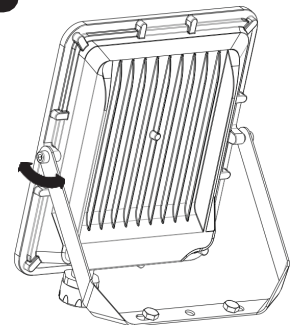

4

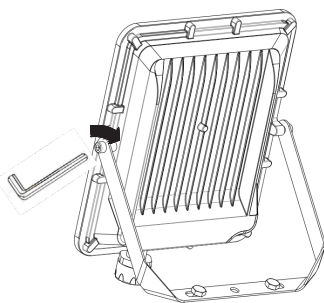

5

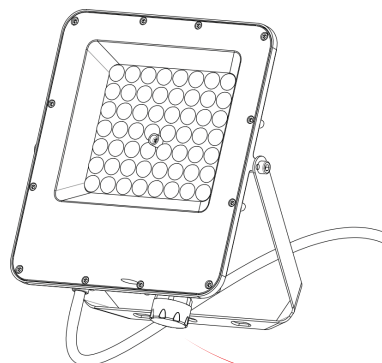

ΔΙΑΓΡΑΜΜΑ

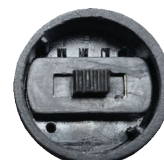
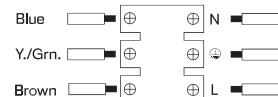

CCT
Διακόπτ

ΜΗΚΟΣ ΚΑΛΩΔΙΟΥ: 120 mm

ΟΔΗΓΙΕΣ ΕΓΚΑΤΑΣΤΑΣΗΣ

Σημαντικό: Ακολουθήστε αυστηρά τα παρακάτω βήματα κατά την εγκατάσταση. Αποφύγετε την άσκηση υπερβολικής δύναμης στο καλώδιο τροφοδοσίας. Η σύνδεση τροφοδοσίας και οι άλλοι εξωτερικοί αγωγοί καλωδίωσης πρέπει να έχουν διατομή τουλάχιστον 3 x 1,0 mm².

- Βεβαιωθείτε ότι η τροφοδοσία είναι απενεργοποιημένη πριν ξεκινήσετε την εγκατάσταση.
- Στερεώστε τα στηρίγματα στην επιθυμητή επιφάνεια.
- Χαλαρώστε τις βίδες και στις δύο πλευρές του βραχίονα.
- Ρυθμίστε τον προβολέα στην επιθυμητή γωνία.
- Σφίξτε τις βίδες και στις δύο πλευρές του βραχίονα για να σταθεροποιήσετε τη θέση.
- Συνδέστε την καλωδίωση του προβολέα σύμφωνα με το διάγραμμα καλωδίωσης.
- Ρυθμίστε την επιθυμητή θερμοκρασία χρώματος χρησιμοποιώντας το διακόπτη CCT.
- Ενεργοποιήστε την τροφοδοσία και δοκιμάστε τον προβολέα.

ΟΔΗΓΙΕΣ ΑΠΟΞΗΛΩΣΗΣ

(Μόνο για την ομάδα εποπτείας της αγοράς)

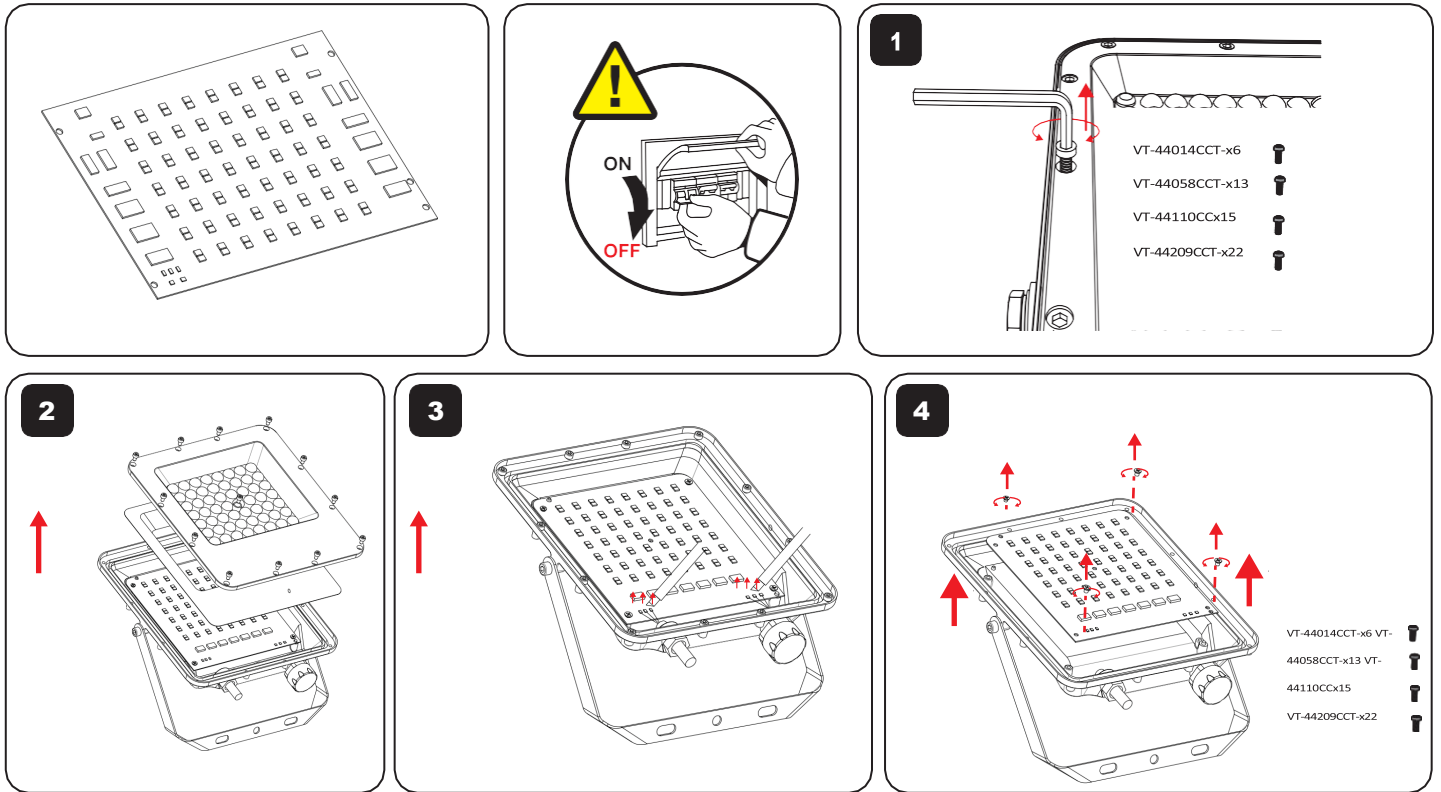

Σημείωση: Η αφαίρεση της πηγής φωτός θα ακυρώσει την εγγύηση.

V-TAC WEST EUROPE LTD. ΣΕ ΠΕΡΙΠΤΩΣΗ ΟΠΟΙΟΥΔΗΠΟΤΕ ΕΡΩΤΗΜΑΤΟΣ/ΠΡΟΒΛΗΜΑΤΟΣ ΣΧΕΤΙΚΑ ΜΕ ΤΟ ΠΡΟΪΟΝ, ΠΑΡΑΚΑΛΟΥΜΕ ΕΠΙΚΟΙΝΩΝΗΣΤΕ ΜΑΖΙ ΜΑΣ ΣΤΗ ΔΙΕΥΘΥΝΣΗ: SUPPORT@V-TAC.EU ΓΙΑ ΠΕΡΙΣΣΟΤΕΡΑ ΠΡΟΪΟΝΤΑ, ΠΑΡΑΚΑΛΟΥΜΕ ΕΠΙΚΟΙΝΩΝΗΣΤΕ ΜΕ ΤΟΝ ΔΙΑΝΟΜΕΑ ΜΑΣ Ή ΤΟΝ ΚΟΝΤΙΝΟΤΕΡΟ ΕΜΠΟΡΟ. V-TAC WEST EUROPE LTD. GROUND FLOOR, 71 LOWER BAGGOT STREET, DUBLIN 02, IRELAND D02 P593

V-TAC UK LTD. ΣΕ ΠΕΡΙΠΤΩΣΗ ΟΠΟΙΟΥΔΗΠΟΤΕ ΕΡΩΤΗΜΑΤΟΣ/ΠΡΟΒΛΗΜΑΤΟΣ ΜΕ ΤΟ ΠΡΟΪΟΝ, ΠΑΡΑΚΑΛΟΥΜΕ ΕΠΙΚΟΙΝΩΝΗΣΤΕ ΜΑΖΙ ΜΑΣ ΣΤΟ SUPPORT@VTACEXPORTS.COM V-TAC, 5A TUNGSTEN PARK, DOWNS ROAD, WITNEY, OXFORDSHIRE, OX29 0AX

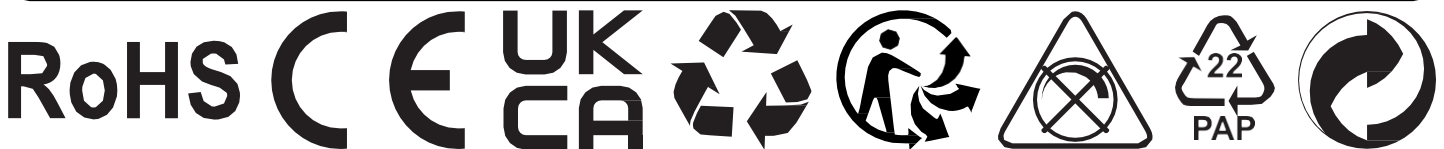

V-TAC

Meaningful Innovation.

HASZNÁLATI ÚTMUTATÓ LED-ES ÁRAMKÖRNYEZETI VILÁGÍTÁS



IP65
RATING

3 IN 1
CCT

MŰSZAKI ADATOK

MODELL	SKU	WATT	HASZNOS LUMEN (SZÉLES KÖP)	SUGÁR ZÁSI SZÖG	ÉLETTARTAM [ÓRA]	DF	CRI	BEMENETI FESZÜLTÉG	MÉRETE	N.W	MAXIMÁLIS SZERELÉSI MAGASSÁG	Kivetített terület	TEST TÍPUS	IK MINŐSÍTÉS
VT-44014CCT	240726	10	730 Lm	90	50 000	>0,9	>80	AC: 220-240 V, 50/60 Hz	147x33x122 mm	192 g	3-5 m	12-34 m	Alumínium	IK06
VT-44058CCT	240736	50 W	4000 Lm	90	50 000	>0,9	>80	AC: 220-240 V, 50/60 Hz	227x33x182 mm	418 g	3-5 m	18,5-50,5 m ²	Alumínium	IK06
VT-44110CCT	240716	100 W	8150 Lm	90	50 000	>0,9	>80	AC: 220-240 V, 50/60 Hz	297 x 33 x 242 mm	825 g	3-5 m	38-103 m	Alumínium	IK06
VT-44209CCT	240706	200 W	16450 Lm	90	50 000	>0,9	>80	AC: 220-240 V, 50/60 Hz	410x33x326 mm	1550 g	3-5 m	100-200 m	Alumínium	IK06

Ezeknek a termékeknek az üzemi hőmérséklet-tartománya -20 °C és +40 °C között van.

BEVEZETÉS ÉS GYÁRTÁSI GARANCIA

Köszönjük, hogy a V-TAC terméket választotta és megvásárolta. A V-TAC a legjobb szolgáltatást nyújtja Önnek. Kérjük, olvassa el figyelmesen ezeket az utasításokat a telepítés megkezdése előtt, és tartsa kéznél ezt a kézikönyvet a jövőbeni referencia céljából. Ha bármilyen további kérdése van, kérjük, vegye fel a kapcsolatot a termék forgalmazójával vagy a helyi kereskedővel, akitől a terméket vásárolta. Ők képzettek és készek a legjobb szolgáltatást nyújtani Önnek. A garancia a vásárlás napjától számított 6 évig érvényes. A garancia nem vonatkozik a helytelen telepítés vagy rendellenes kopás okozta károkra. A vállalat nem vállal garanciát a termék helytelen eltávolítása és telepítése miatt bekövetkezett felületi károkra. A termékek napi 10-12 órás működésre alkalmasak. A termék napi 24 órás használata a garancia elvesztését vonja maga után. A termékre csak gyártási hibákra vonatkozik a garancia.

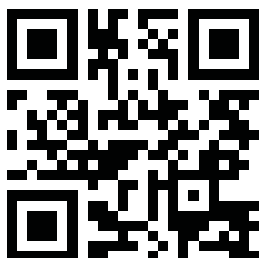

TÖBB NYELVŰ KÉZIKÖNYV QR-KÓD

Kérjük, olvassa be a QR-kódot, hogy hozzáférjen a többnyelvű kézikönyvhöz.



FR

Cet appareil, ses accessoires et câbles se recyclent

À DÉPOSER EN MAGASIN

À DÉPOSER EN DÉCHÈTERIE





OU



Points de collecte sur www.quefairedemesdechets.fr
Privilégiez la réparation ou le don de votre appareil !

A TERMÉKHEZ KAPCSOLÓDÓ BÁRMELY KÉRDÉS/PROBLÉMA ESETÉN KÉRJÜK, FORDULJON HOZZÁNK: SUPPORT@V-TAC.EU
TOVÁBBI TERMÉKEKÉRT, ÉS KÉRDÉSEKÉRT KÉRJÜK, FORDULJON FORGALMAZÓNKHOZ VAGY A LEGKÖZELEBBI
KERESKEDŐHÖZ. V-TAC EUROPE LTD. BULGÁRIA, PLOVDIV 4000, BUL.L.KARAVELOW 9B

FIGYELMEZTETÉS

- A telepítés megkezdése előtt feltétlenül kapcsolja ki az áramellátást.
- A telepítést szakképzett villanyszerelőnek kell elvégeznie.
- A lámpatestben található fényforrást csak a gyártó, annak szervizképviselője vagy hasonlóan képzett szakember cserélheti ki.
- A lámpatest külső rugalmas kábele vagy vezetéke nem cserélhető; ha a vezeték megsérült, a lámpatestet meg kell semmisíteni.
- A sorkapocs nem tartozék.
- A telepítés során gondoskodni kell a megfelelő földelésről.
- Kültéri használatra.
- Cserélje ki az összes repedt védőburkolatot. 
- A megvilágított tárgytól való minimális távolság 1 m. 

MEGJEGYZÉS

- A fojtogatás veszélyének csökkentése érdekében a lámpatesthez csatlakozó rugalmas vezetéket hatékonyan rögzíteni kell a falhoz, ha a vezeték karnyújtásnyi távolságon belül van.
- A termék IP-védelmének fenntartása érdekében a kábelátvezetést/tömítést az alsó oldalon kell felszerelni.

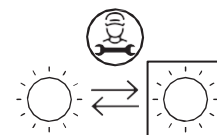

Cserélhető fényforrás
szakember által

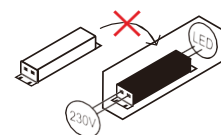

Nem cserélhető vezérlőegység

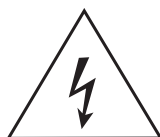

Figyelem, áramütés veszélye!



Ez a jelölés azt jelzi, hogy ezt a terméket nem szabad a háztartási hulladékkal együtt ártalmatlanítani.

TELEPÍTÉSI ÁBRA

1

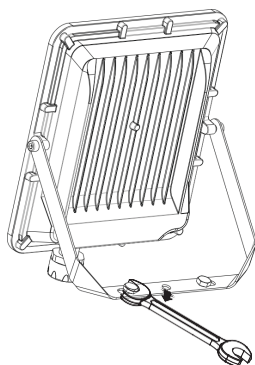

2

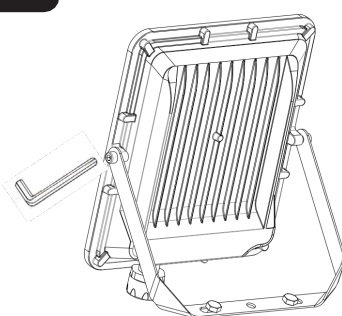

3

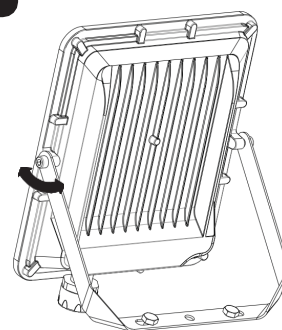

4

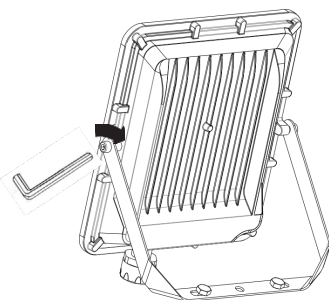

5

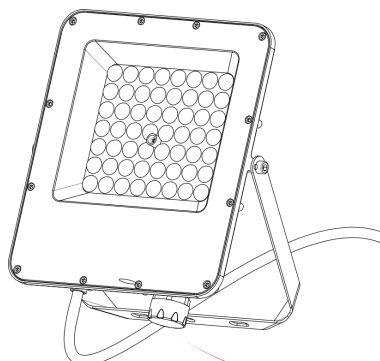

KÁBELELRENDELÉS

Blue	⊕	⊕	N	⊖
Y./Grn.	⊕	⊕	⊖	⊖
Brown	⊕	⊕	L	⊖

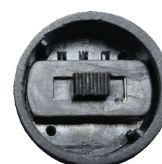

CCT
Kapcs

VEZETÉK HOSSZA: 120

TELEPÍTÉSI ÚTMUTATÓ

Fontos: A telepítés során szigorúan kövesse az alábbi lépéseket. Ne alkalmazzon túlzott erőt a tápkábelre. Az áramellátó csatlakozásnak és más külső vezetéknek legalább 3 x 1,0 mm²-es keresztmetszetűnek kell lenniük.

- A telepítés megkezdése előtt győződjön meg arról, hogy a készülék ki van kapcsolva.
- Rögzítse a konzolokat a kívánt felülethez.
- Lazítsa meg a konzol mindkét oldalán található csavarokat.
- Állítsa be a reflektort a kívánt szögbe.
- Húzza meg a konzol mindkét oldalán található csavarokat, hogy rögzítse a pozíciót.
- Csatlakoztassa a reflektor vezetékeit a bekötési rajz szerint.
- Állítsa be a kívánt színhőmérsékletet a CCT kapcsolóval.
- Kapcsolja be az áramot, és tesztelje a reflektort.

LESZERELÉSI ÚTMUTATÓ

(Kizárólag a piacfelügyeleti csapat számára)

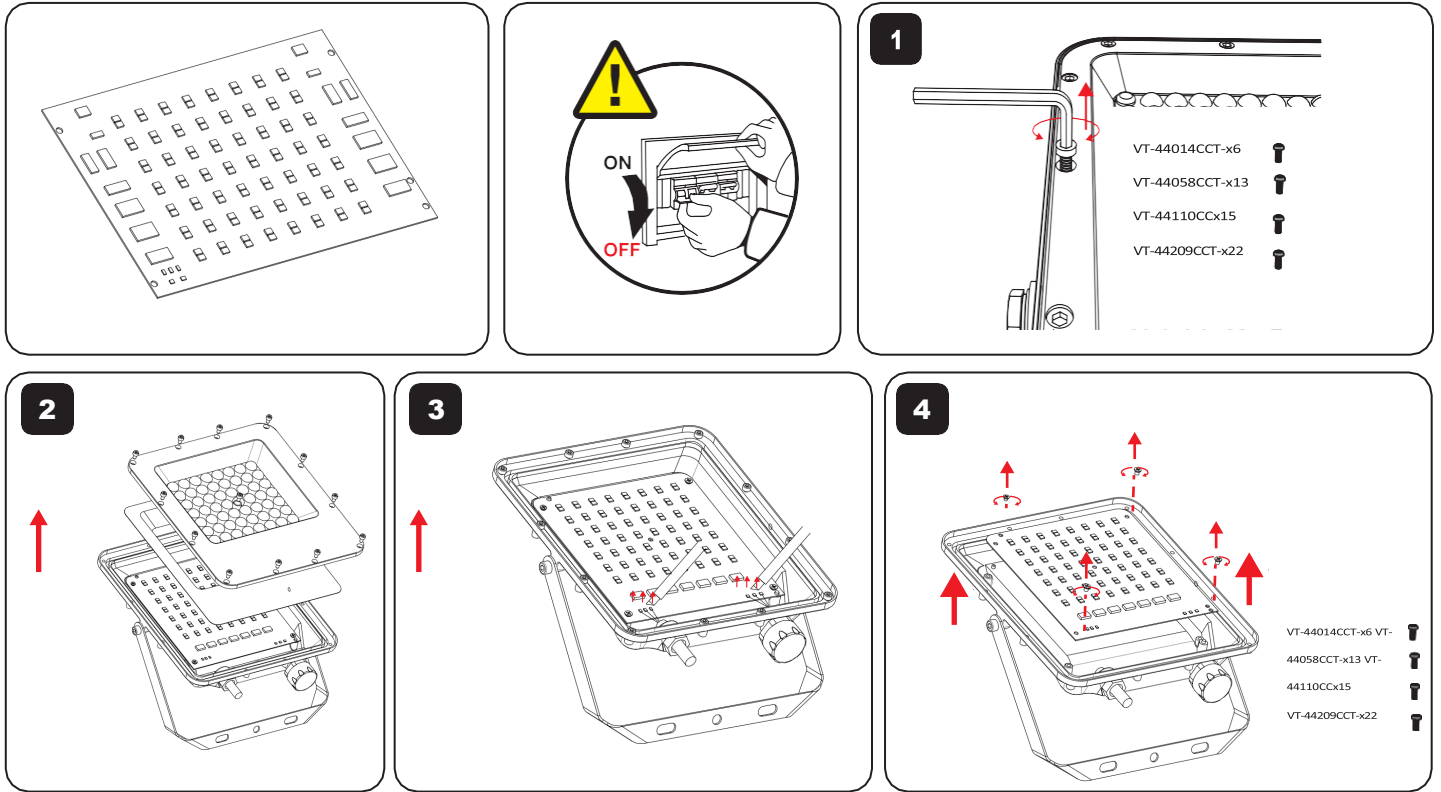

Megjegyzés: A fényforrás eltávolítása a garancia elvesztését vonja maga után.

V-TAC WEST EUROPE LTD. A TERMÉKHEZ KAPCSOLÓDÓ BÁRMELY KÉRDÉS/PROBLÉMA ESETÉN KÉRJÜK, FORDULJON HOZZÁNK:
SUPPORT@V-TAC.EU TOVÁBBI TERMÉKEKÉRT, ÉS KÉRDÉSEKÉRT KÉRJÜK, FORDULJON FORGALMAZÓNKHOZ VAGY A LEGKÖZELEBBI
KERESKEDŐHÖZ. V-TAC WEST EUROPE LTD. GROUND FLOOR, 71 LOWER BAGGOT STREET, DUBLIN 02, ÍRORSZÁG DO2 P593

V-TAC UK LTD. A TERMÉKKEL KAPCSOLATOS BÁRMELY KÉRDÉS/PROBLÉMA ESETÉN KÉRJÜK, FORDULJON HOZZÁNK A
SUPPORT@VTACEXPORIS.COM CÍMEN. V-TAC, 5A TUNGSTEN PARK, DOWNS ROAD, WITNEY, OXFORDSHIRE, OX29 0AX



V-TAC

Meaningful Innovation.

MANUALE DI ISTRUZIONI

PROIETTORE LED



IP65
RATING



DATI TECNICI

MODELLO	SKU	W	LUMEN UTILI (SECONDO AMPPIO)	ANGOLO DEL FASCIO	DURATA [ORE]	DF	CRI	TENSIONE DI INGRESSO	DIMENSIONI	N.W	ALTEZZA MASSIMA DI MONTAGGIO	SUPERFICIE PROIETTATA	TIPO DI CORPO	CLASSE IK
VT-44014CCT	240726	10	730 Lm	90	50.000	>0,9	>80	CA: 220-240 V, 50/60 Hz	147 x 33 x 122 mm	192 g	3-5 m	12-34 m ²	Alluminio	IK06
VT-44058CCT	240736	50 W	4000 Lm	90	50.000	>0,9	>80	CA: 220-240 V, 50/60 Hz	227 x 33 x 182 mm	418 g	3-5 m	18,5-50,5 m ²	Alluminio	IK06
VT-44110CCT	240716	100 W	8150 Lm	90	50.000	>0,9	>80	CA: 220-240 V, 50/60 Hz	297 x 33 x 242 mm	825 g	3-5 m	38-103 m ²	Alluminio	IK06
VT-44209CCT	240706	200 W	16450 Lm	90	50.000	>0,9	>80	CA: 220-240 V, 50/60 Hz	410 x 33 x 326 mm	1550 g	3-5 m	100-200 m ²	Alluminio	IK06

L'intervallo di temperatura di esercizio per questi articoli è compreso tra -20 °C e +40 °C.

INTRODUZIONE E GARANZIA

Grazie per aver scelto e acquistato un prodotto V-TAC. V-TAC vi offrirà il miglior servizio possibile. Leggete attentamente queste istruzioni prima di iniziare l'installazione e conservate questo manuale a portata di mano per riferimento futuro. Per qualsiasi altra domanda, contattate il nostro rivenditore o il fornitore locale presso il quale avete acquistato il prodotto. Sono personale qualificato e pronto a offrirvi il miglior servizio possibile. La garanzia è valida per 6 anni dalla data di acquisto. La garanzia non si applica ai danni causati da un'installazione errata o da un'usura anomala. L'azienda non fornisce alcuna garanzia per i danni causati a qualsiasi superficie a causa di una rimozione e installazione errata del prodotto. I prodotti sono adatti per un funzionamento giornaliero di 10-12 ore. L'utilizzo del prodotto per 24 ore al giorno invaliderà la garanzia. Questo prodotto è garantito solo per i difetti di fabbricazione.

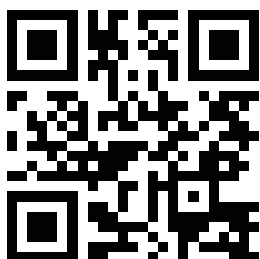

MANUALE MULTILINGUE CODICE QR

Si prega di scansionare il codice QR per accedere al manuale in più lingue.



FR

Cet appareil, ses accessoires et cordons se recyclent

À DÉPOSER EN MAGASIN

À DÉPOSER EN DÉCHÈTERIE





OU



Points de collecte sur www.quefairedemesdechets.fr
Privilégiez la réparation ou le don de votre appareil !

AVVERTENZA

- Assicurarsi di spegnere l'alimentazione prima di iniziare l'installazione.
- L'installazione deve essere eseguita da un elettricista qualificato.
- La sorgente luminosa contenuta in questo apparecchio di illuminazione deve essere sostituita esclusivamente dal produttore o dal suo agente di assistenza o da una persona qualificata simile.
- Il cavo flessibile esterno o il cordone di questo apparecchio di illuminazione non possono essere sostituiti; se il cordone è danneggiato, l'apparecchio di illuminazione deve essere distrutto.
- Morsettieria non inclusa.
- Durante l'installazione è necessario garantire una corretta messa a terra.
- Per uso esterno.
- Sostituire qualsiasi schermo protettivo incrinato. 
- Distanza minima dagli oggetti illuminati 1 m. 

NOTA

- Per ridurre il rischio di strangolamento, il cavo flessibile collegato a questo apparecchio di illuminazione deve essere fissato saldamente alla parete se si trova a portata di mano.
- Per mantenere la protezione IP del prodotto, l'ingresso cavi/pressacavo deve essere installato sul lato inferiore.

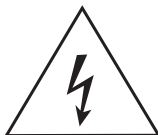
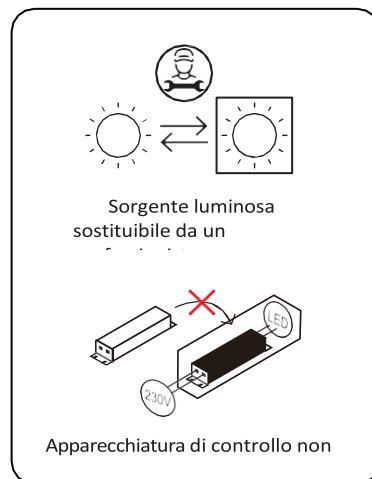

Attenzione, pericolo di scossa elettrica.



Questo simbolo indica che il prodotto non deve essere smaltito insieme ai rifiuti domestici.

SCHEMA DI INSTALLAZIONE

1

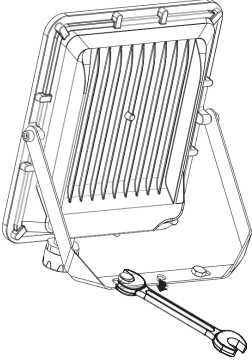

2



3

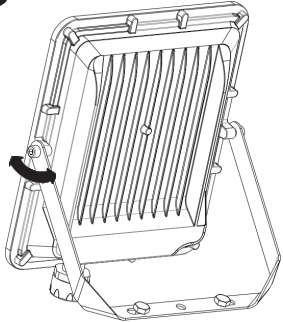

4

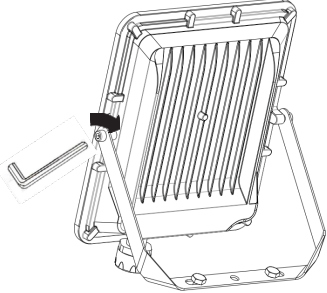

5

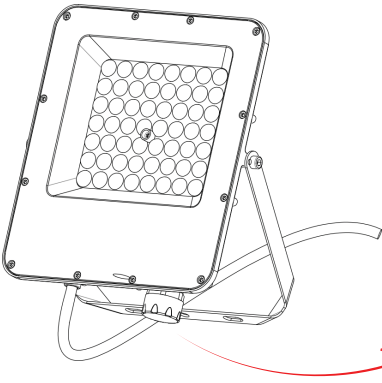

SCHEMA

Blue	⊖	⊕	⊕	N	⊖
Y./Grn.	⊖	⊕	⊕	⊕	⊖
Brown	⊖	⊕	⊕	L	⊖

CCT Interrut

LUNGHEZZA DEL CAVO:

V-TAC

Meaningful Innovation.

INSTRUKCJA OBSŁUGI

LED FLOOD LIGHT



IP65
RATING



DANE TECHNICZNE

MODEL	SKU	WAT	POŻĄDA NA LUMEN (SZEROKI KĄT)	KĄT ŚWIECENIA	ŻYWIOTNOŚĆ [GODZINY]	DF	CRI	NAPIĘCIE WEJŚCIOWE	WYMIARY	N.W	MAKSYMALNA WYSOKOŚĆ MONTAŻOWA	POWIERZCHNIA PROJEKTOWA	TYP OBUDOWY	KLAS A IK
VT-44014CCT	240726	10	730 lm	90	50 000	>0,9	>80	AC: 220-240 V, 50/60 Hz	147 x 33 x 122 mm	192 g	3-5 m	12-34 m ²	Aluminium	IK06
VT-44058CCT	240736	50 W	4000 lm	90	50 000	>0,9	>80	AC: 220-240 V, 50/60 Hz	227 x 33 x 182 mm	418 g	3-5 m	18,5-50,5 m ²	Aluminium	IK06
VT-44110CCT	240716	100 W	8150 lm	90	50 000	>0,9	>80	AC: 220-240 V, 50/60 Hz	297 x 33 x 242 mm	825 g	3-5 m	38-103 m ²	Aluminium	IK06
VT-44209CCT	240706	200 W	16450 lm	90	50 000	>0,9	>80	AC: 220-240 V, 50/60 Hz	410 x 33 x 326 mm	1550 g	3-5 m	100-200 m ²	Aluminium	IK06

Zakres temperatur roboczych dla tych produktów wynosi od -20°C do +40°C.

WPROWADZENIE I GWARANCJA

Dziękujemy za wybór i zakup produktu V-TAC. V-TAC zapewni Państwu najlepszą obsługę. Przed rozpoczęciem instalacji prosimy o uważne przeczytanie niniejszej instrukcji i zachowanie jej w celu wykorzystania w przyszłości. W przypadku dodatkowych pytań prosimy o kontakt z naszym dystrybutorem lub lokalnym sprzedawcą, od którego zakupiono produkt. Są oni przeszkoleni i gotowi zapewnić Państwu najlepszą obsługę. Gwarancja obowiązuje przez 6 lat od daty zakupu. Gwarancja nie obejmuje uszkodzeń spowodowanych nieprawidłową instalacją lub nienormalnym zużyciem. Firma nie udziela gwarancji na uszkodzenia powierzchni spowodowane nieprawidłowym demontażem i instalacją produktu. Produkty są przystosowane do codziennej pracy przez 10-12 godzin. Używanie produktu przez 24 godziny na dobę spowoduje utratę gwarancji. Niniejszy produkt jest objęty gwarancją wyłącznie na wady produkcyjne.

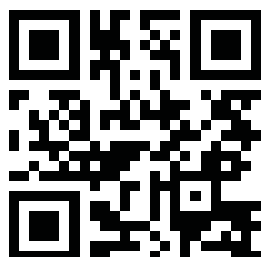

**WIELOJĘZYCZNA
INSTRUKCJA QR CODE**
Proszę zeskanować kod QR,
aby uzyskać dostęp do
instrukcji w wielu językach.



FR
Cet appareil,
ses accessoires
et cordons
se recyclent

À DÉPOSER
EN MAGASIN



À DÉPOSER
EN DÉCHÈTERIE





OU

Points de collecte sur www.quefairedemesdechets.fr
Privilégiez la réparation ou le don de votre appareil !

W PRZYPADKU JAKIKOLWIEK PYTAŃ/PROBLEMÓW ZWIĄZANYCH Z PRODUKTEM PROSIMY O KONTAKT POD ADRESEM:
SUPPORT@V-TAC.EU. ABY UZYSKAĆ WIĘCEJ INFORMACJI NA TEMAT ASORTYMENTU PRODUKTÓW, PROSIMY O KONTAKT Z
NASZYM DYSTRYBUTOREM LUB NAJBLIŻSZYM DEALEREM. V-TAC EUROPE LTD. BUŁGARIA, PLOVDIV 4000, BUL.L.KARAVELOW 9B

OSTRZEŻENIE

- Przed rozpoczęciem instalacji należy wyłączyć zasilanie.
- Instalacja musi być wykonana przez wykwalifikowanego elektryka.
- Źródło światła zawarte w tej oprawie oświetleniowej może być wymieniane wyłącznie przez producenta, jego przedstawiciela serwisowego lub podobną wykwalifikowaną osobę.
- Zewnętrznego elastycznego kabla lub przewodu tej oprawy nie można wymienić; jeśli przewód jest uszkodzony, oprawę należy zniszczyć.
- Blok zacisków nie wchodzi w skład zestawu.
- Podczas instalacji należy zapewnić prawidłowe uziemienie.
- Do użytku na zewnątrz.
- Wymień każdą pękniętą osłonę ochronną. 
- Minimalna odległość od oświetlanych obiektów wynosi 1 m. 

UWAGA

- Aby zmniejszyć ryzyko uduszenia, elastyczne przewody podłączone do tej oprawy oświetleniowej powinny być skutecznie przymocowane do ściany, jeśli przewody znajdują się w zasięgu ręki.
- Aby zachować ochronę IP produktu, przepust kablowy/dławik należy zainstalować od spodu.



Uwaga, istnieje ryzyko porażenia prądem elektrycznym.



To oznaczenie wskazuje, że produkt nie należy wyrzucać wraz z innymi odpadami domowymi.

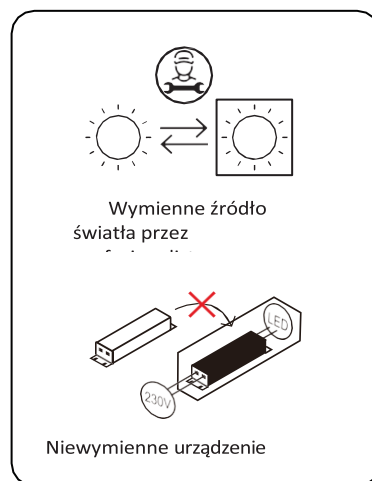

SCHEMAT INSTALACYJNY

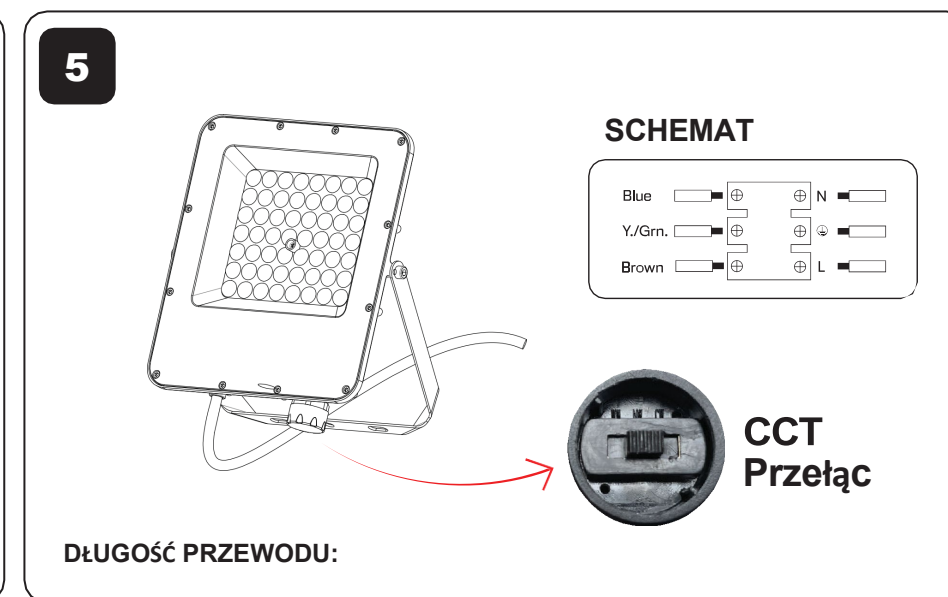
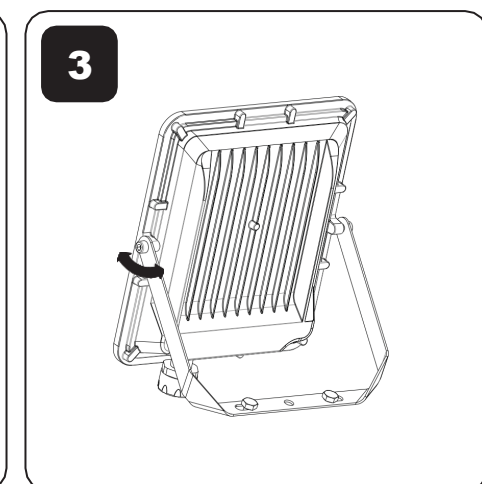
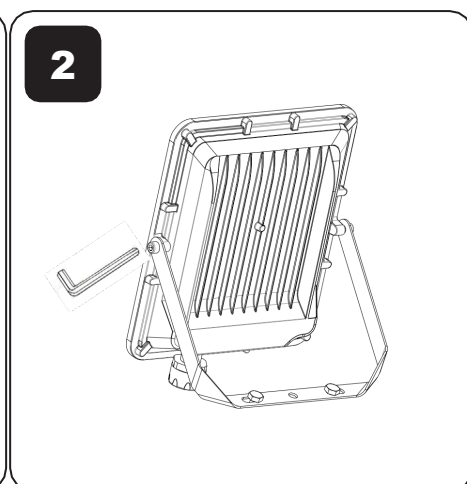
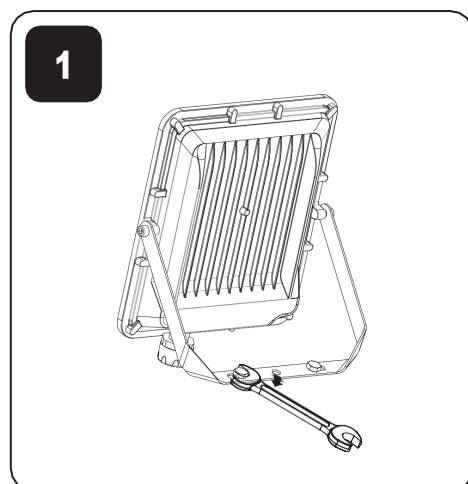

INSTRUKCJA INSTALACJI

Ważne: Podczas instalacji należy ściśle przestrzegać poniższych instrukcji. Należy unikać wywierania nadmiernej siły na kabel zasilający. Połączenie zasilające i inne zewnętrzne przewody muszą mieć przekrój co najmniej 3 x 1,0 mm².

- Przed rozpoczęciem instalacji upewnij się, że zasilanie jest wyłączone.
- Przymocuj wsporniki do wybranej powierzchni.
- Poluzuj śruby po obu stronach wspornika.
- Ustaw reflektor pod żądanym kątem.
- Dokręć śruby po obu stronach wspornika, aby zabezpieczyć pozycję.
- Podłącz przewody reflektora zgodnie ze schematem połączeń.
- Ustaw żądaną temperaturę barwową za pomocą przełącznika CCT.
- Włącz zasilanie i przetestuj reflektor.

INSTRUKCJA DEMONTAŻU

(Wyłącznie dla zespołu ds. nadzoru rynku)

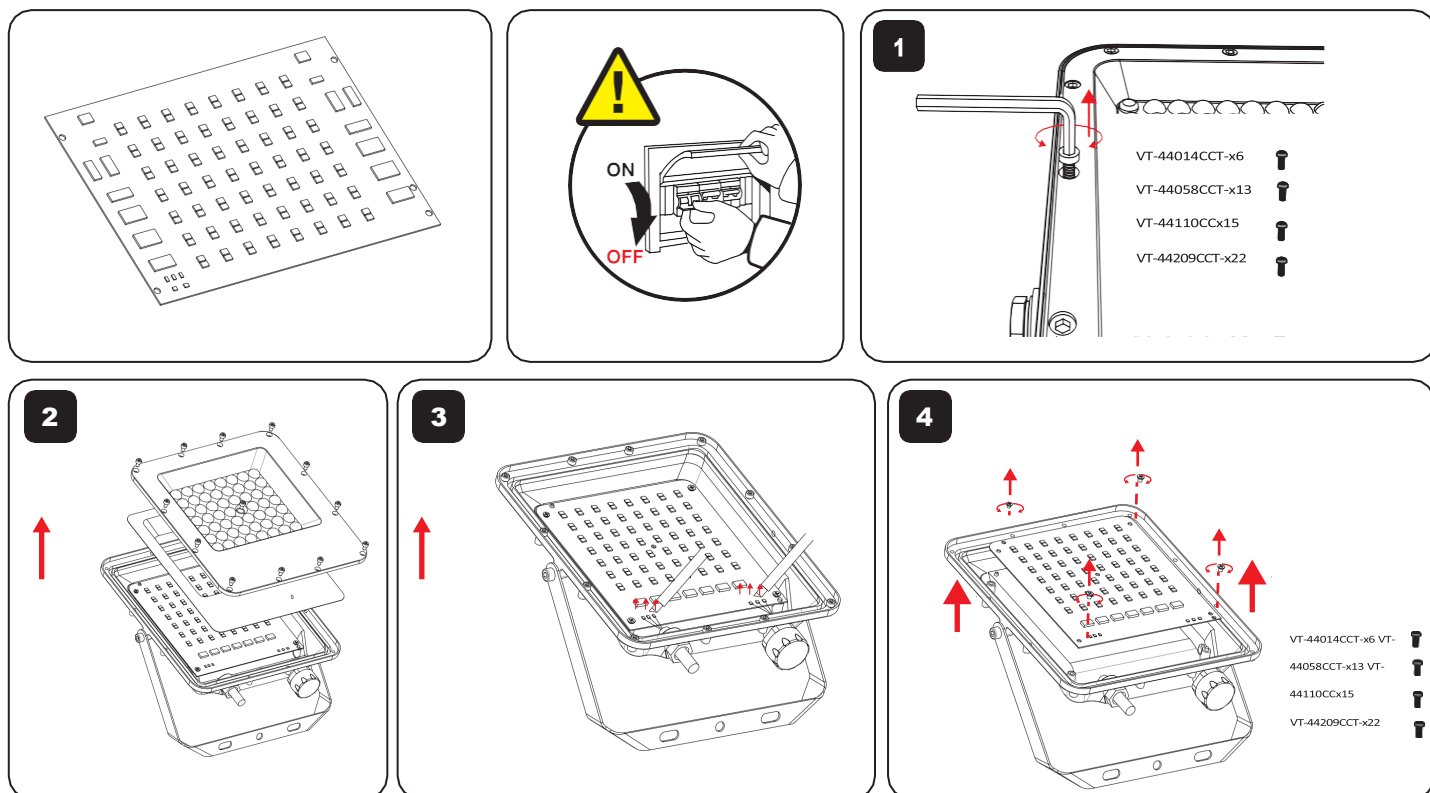

Uwaga: Usunięcie źródła światła spowoduje utratę gwarancji.

V-TAC WEST EUROPE LTD. W PRZYPADKU JAKICHKOLWIEK PYTAŃ/PROBLEMÓW ZWIĄZANYCH Z PRODUKTEM PROSIMY O KONTAKT POD ADRESEM: SUPPORT@V-TAC.EU. ABY UZYSKAĆ WIĘCEJ INFORMACJI NA TEMAT ASORTYMENTU PRODUKTÓW, PROSIMY O KONTAKT Z NASZYM DYSTRYBUTOREM LUB NAJBLIŻSZYM DEALEREM. V-TAC WEST EUROPE LTD. PARTER, 71 LOWER BAGGOT STREET, DUBLIN 02, IRLANDIA D02 P593

V-TAC UK LTD. W PRZYPADKU JAKICHKOLWIEK PYTAŃ/PROBLEMÓW ZWIĄZANYCH Z PRODUKTEM PROSIMY O KONTAKT POD ADRESEM SUPPORT@VTACEXPORTS.COM V-TAC, 5A TUNGSTEN PARK, DOWNS ROAD, WITNEY, OXFORDSHIRE, OX29 0AX



V-TAC

Meaningful Innovation.

MANUAL DE INSTRUÇÕES LUZ LED DE ILUMINAÇÃO



IP65
RATING



DADOS TÉCNICOS

MODELO	SKU	WATTS	LÚMEN ÚTIL (BECOME LARGO)	ÂNGULO DO FEIXE	VIDA ÚTIL [HORAS]	DF	CRI	TENSÃO DE ENTRADA	DIMENSÃO	N.W	ALTURA MÁXIMA DE MONTAGEM	ÁREA PROJETADA	TIPO DE CORPO	CLAS SIFICAÇÃO IK
VT-44014CCT	240726	10W	730 Lm	90	50 000	>0,9	>80	CA: 220-240 V, 50/60 Hz	147 x 33 x 122 mm	192 g	3-5 m	12-34 m ²	Alumínio	IK06
VT-44058CCT	240736	50 W	4000 Lm	90	50.000	>0,9	>80	CA: 220-240 V, 50/60 Hz	227 x 33 x 182 mm	418 g	3-5 m	18,5-50,5 m ²	Alumínio	IK06
VT-44110CCT	240716	100 W	8150 Lm	90	50.000	>0,9	>80	CA: 220-240 V, 50/60 Hz	297 x 33 x 242 mm	825 g	3-5 m	38-103 m ²	Alumínio	IK06
VT-44209CCT	240706	200 W	16450 Lm	90	50.000	>0,9	>80	CA: 220-240 V, 50/60 Hz	410 x 33 x 326 mm	1550 g	3-5 m	100-200 m ²	Alumínio	IK06

A faixa de temperatura de operação para esses itens é de -20 °C a +40 °C.

INTRODUÇÃO E GARANTIA

Obrigado por escolher e comprar um produto V-TAC. A V-TAC irá atendê-lo da melhor forma possível. Leia atentamente estas instruções antes de iniciar a instalação e mantenha este manual à mão para referência futura. Se tiver alguma outra dúvida, entre em contacto com o nosso revendedor ou fornecedor local onde adquiriu o produto. Eles são treinados e estão prontos para atendê-lo da melhor forma possível. A garantia é válida por 6 anos a partir da data de compra. A garantia não se aplica a danos causados por instalação incorreta ou desgaste anormal. A empresa não oferece garantia contra danos a qualquer superfície devido à remoção e instalação incorretas do produto. Os produtos são adequados para 10-12 horas de funcionamento diário. O uso do produto por 24 horas por dia invalidará a garantia. Este produto tem garantia apenas para defeitos de fabricação.

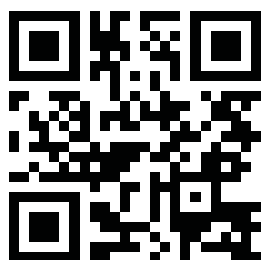

CÓDIGO QR DO MANUAL EM VÁRIOS IDIOMAS

Digitalize o código QR para
aceder ao manual em vários
idiomas.



FR

Cet appareil,
ses accessoires
et cordons
se recyclent

À DÉPOSER
EN MAGASIN

À DÉPOSER
EN DÉCHÈTERIE





OU



Points de collecte sur www.quefairedemesdechets.fr
Privilégiez la réparation ou le don de votre appareil !

EM CASO DE QUALQUER DÚVIDA/PROBLEMA COM O PRODUTO, ENTRE EM CONTATO CONOSCO ATRAVÉS DO E-MAIL:
SUPPORT@V-TAC.EU PARA MAIS INFORMAÇÕES SOBRE A GAMA DE PRODUTOS, ENTRE EM CONTATO COM O NOSSO
DISTRIBUIDOR OU COM O REVENDEDOR MAIS PRÓXIMO. V-TAC EUROPE LTD. BULGÁRIA, PLOVDIV 4000, BUL.L.KARAVELOW 9B

AVISO

- Certifique-se de desligar a alimentação antes de iniciar a instalação.
- A instalação deve ser realizada por um electricista qualificado.
- A fonte de luz contida nesta luminária só deve ser substituída pelo fabricante ou pelo seu agente de assistência ou por uma pessoa qualificada semelhante.
- O cabo flexível externo ou fio desta luminária não pode ser substituído; se o fio estiver danificado, a luminária deve ser destruída.
- Bloco de terminais não incluído.
- Deve ser assegurada uma ligação à terra adequada durante toda a instalação.
- Para uso ao ar livre.
- Substitua qualquer proteção protetora rachada. 
- Distância mínima de objetos iluminados: 1 m. 

NOTA

- Para reduzir o risco de estrangulamento, a cablagem flexível ligada a esta luminária deve ser fixada de forma eficaz à parede se a cablagem estiver ao alcance da mão.
- Para manter a proteção IP do produto, a entrada/glândula do cabo deve ser instalada na parte inferior.

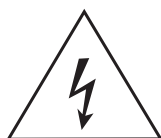

Cuidado, risco de choque elétrico.



Esta marcação indica que este produto não deve ser eliminado juntamente com outros resíduos domésticos.



DIAGRAMA DE INSTALAÇÃO



INSTRUÇÕES DE INSTALAÇÃO

Importante: Siga rigorosamente os passos abaixo durante a instalação. Evite aplicar força excessiva ao cabo de alimentação. A ligação de alimentação e outros condutores de cablagem externos devem ter, no mínimo, 3 x 1,0 mm².

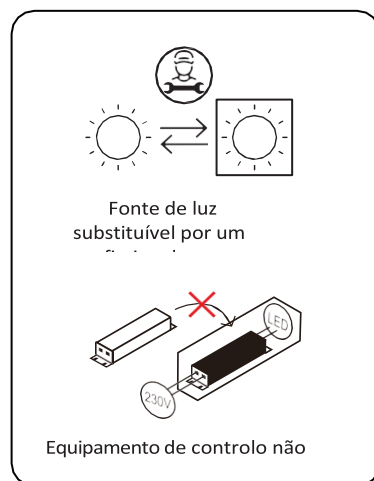
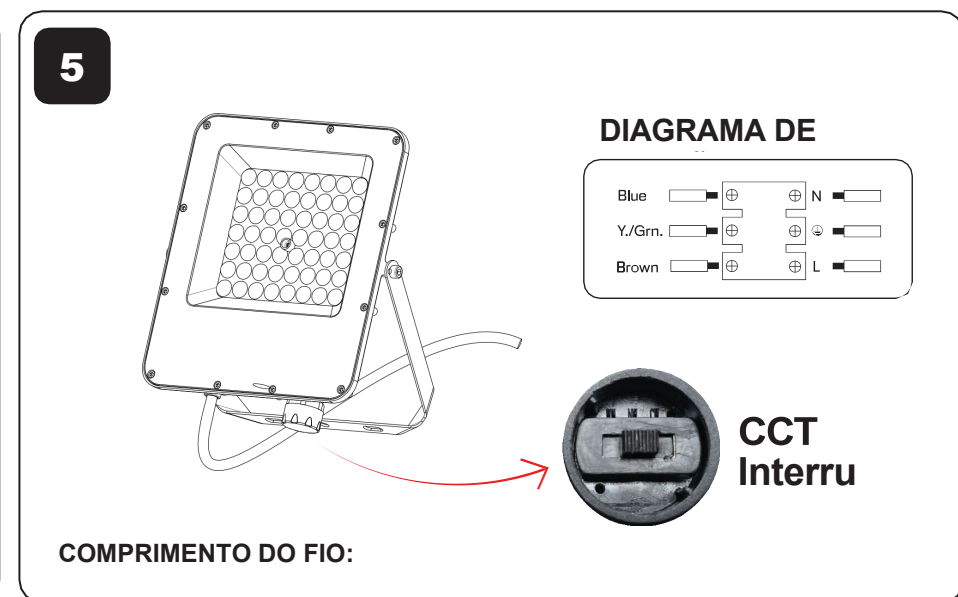
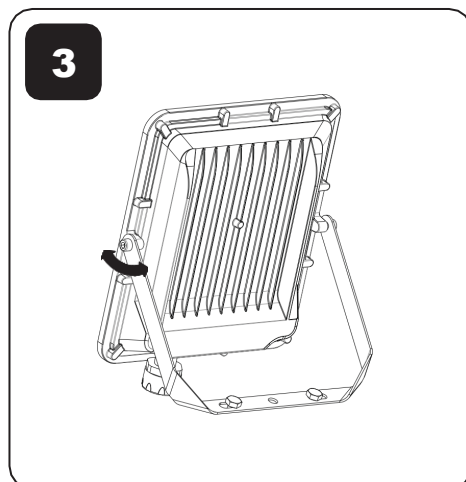
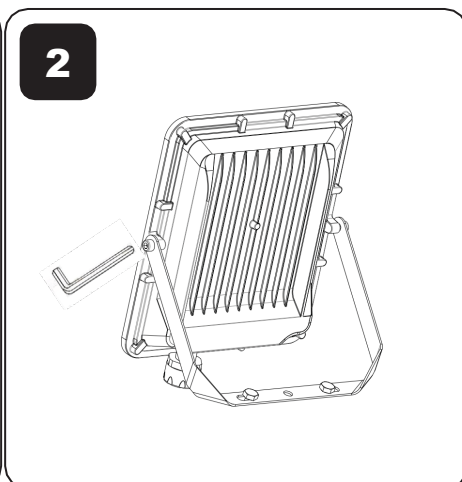
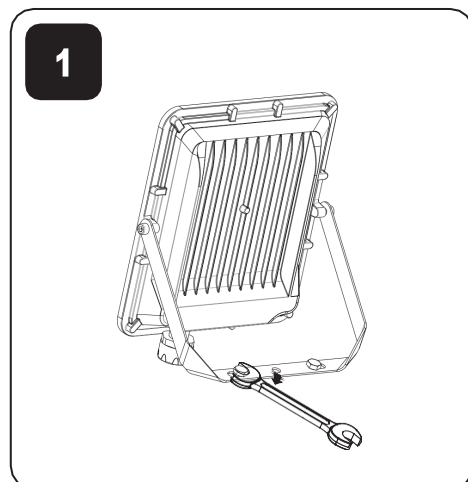
- Certifique-se de que a alimentação está desligada antes de iniciar a instalação.
- Prenda os suportes à superfície desejada.
- Desaperte os parafusos em ambos os lados do suporte.
- Ajuste o holofote no ângulo desejado.
- Aperte os parafusos em ambos os lados do suporte para fixar a posição.
- Ligue a cablagem do projetor de acordo com o diagrama de cablagem.
- Defina a temperatura de cor desejada usando o interruptor CCT.
- Ligue a alimentação e teste o projetor.

INSTRUÇÕES DE DESMONTAGEM

(Apenas para a equipa de fiscalização do mercado)

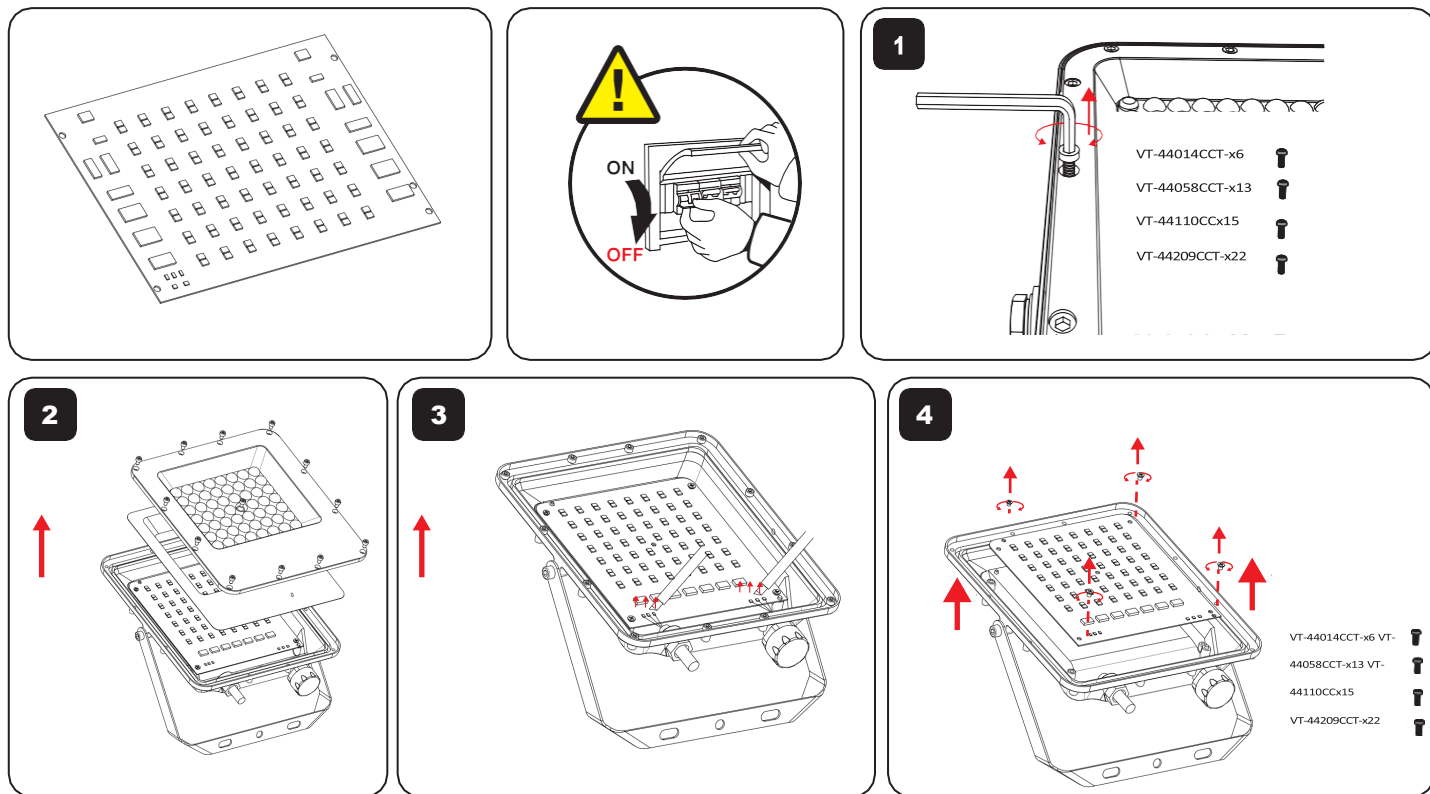

Nota: A remoção da fonte de luz invalidará a garantia.

V-TAC WEST EUROPE LTD. EM CASO DE QUALQUER DÚVIDA/PROBLEMA COM O PRODUTO, ENTRE EM CONTATO CONOSCO ATRAVÉS DO E-MAIL: SUPPORT@V-TAC.EU PARA MAIS INFORMAÇÕES SOBRE A GAMA DE PRODUTOS, ENTRE EM CONTATO COM O NOSSO DISTRIBUIDOR OU COM O REVENDEDOR MAIS PRÓXIMO. V-TAC WEST EUROPE LTD. TÉRREO, 71 LOWER BAGGOT STREET, DUBLIN 02, IRLANDA DO2 P593

V-TAC UK LTD. EM CASO DE QUALQUER DÚVIDA/PROBLEMA COM O PRODUTO, ENTRE EM CONTATO CONOSCO ATRAVÉS DO E-MAIL: SUPPORT@VTACEXPORTS.COM V-TAC, 5A TUNGSTEN PARK, DOWNS ROAD, WITNEY, OXFORDSHIRE, OX29 0AX



V-TAC

Meaningful Innovation.

MANUAL DE INSTRUCȚIUNI

LED FLOOD LIGHT



6 YEAR WARRANTY*



IP65
RATING

3 IN 1
CCT

DATE TEHNICE

MODEL	SKU	W	LUMEN UTIL (BEAM CONIC)	UNGHII UL FASCIC ULULUI	DURATA DE VIAȚĂ [ORE]	DF	CRI	TENSIUNEA ZĂ DE INTRARE	DIMENSIUNE	N.W	ÎNĂLȚIME MAXIMĂ DE MONTARE	SUPRAFAȚĂ PROIECT ATĂ	TIP CORP	CLASĂ IFICARE IK
VT-44014CCT	240726	10	730 Lm	90	50.000	>0,9	>80	AC: 220-240 V, 50/60 Hz	147 x 33 x 122 mm	192	3-5 m	12-34 m ²	Aluminiu	IK06
VT-44058CCT	240736	50W	4000 Lm	90	50.000	>0,9	>80	AC: 220-240 V, 50/60 Hz	227 x 33 x 182 mm	418 g	3-5 m	18,5-50,5 m ²	Aluminiu	IK06
VT-44110CCT	240716	100 W	8150 Lm	90	50.000	>0,9	>80	Curent alternativ: 220-240 V, 50/60 Hz	297 x 33 x 242 mm	825 g	3-5 m	38-103 m ²	Aluminiu	IK06
VT-44209CCT	240706	200 W	16450 Lm	90	50.000	>0,9	>80	AC: 220-240 V, 50/60 Hz	410 x 33 x 326 mm	1550 g	3-5 m	100-200 m ²	Aluminiu	IK06

Intervalul de temperatură de funcționare pentru aceste articole este de la -20 °C la +40 °C.

INTRODUCERE ȘI GARANȚIE

Vă mulțumim că ați ales și ați cumpărat produsul V-TAC. V-TAC vă va oferi cele mai bune servicii. Vă rugăm să citiți cu atenție aceste instrucțiuni înainte de a începe instalarea și să păstrați acest manual la îndemână pentru referințe viitoare. Dacă aveți alte întrebări, vă rugăm să contactați distribuitorul nostru sau vânzătorul local de la care ați achiziționat produsul. Aceștia sunt instruiți și pregătiți să vă ofere cele mai bune servicii. Garanția este valabilă timp de 6 ani de la data achiziției. Garanția nu se aplică daunelor cauzate de instalarea incorectă sau uzura anormală. Compania nu oferă nicio garanție împotriva deteriorării oricărei suprafețe din cauza demontării și instalării incorecte a produsului. Produsele sunt potrivite pentru o funcționare zilnică de 10-12 ore. Utilizarea produsului timp de 24 de ore pe zi va anula garanția. Acest produs este garantat numai pentru defecte de fabricație.

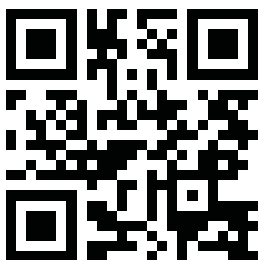

MANUAL MULTILINGV COD QR

Vă rugăm să scanați codul QR pentru a accesa manualul în mai multe limbi.



FR

Cet appareil,
ses accessoires
et cordons
se recyclent

À DÉPOSER
EN MAGASIN



À DÉPOSER
EN DÉCHÈTERIE



OU

Points de collecte sur www.quefairedemesdechets.fr
Privilégiez la réparation ou le don de votre appareil !

ÎN CAZUL ORICĂREI ÎNTREBĂRI/PROBLEME LEGATE DE PRODUS, VĂ RUGĂM SĂ NE CONTACTAȚI LA: SUPPORT@V-TAC.EU PENTRU MAI MULTE PRODUSE DIN GAMĂ, VĂ RUGĂM SĂ CONTACTAȚI DISTRIBUTORUL NOSTRU SAU CEL MAI APROPIAT DEALER. V-TAC EUROPE LTD. BULGARIA, PLOVDIV 4000, BUL.L.KARAVELOW 9B

AVERTISMENT

- Asigurați-vă că ați oprit alimentarea cu energie electrică înainte de a începe instalarea.
- Instalarea trebuie efectuată de un electrician calificat.
- Sursa de lumină conținută în acest corp de iluminat trebuie înlocuită numai de către producător sau agentul său de service sau o persoană calificată similară.
- Cablul flexibil extern sau cordonul acestui corp de iluminat nu poate fi înlocuit; dacă cordonul este deteriorat, corpul de iluminat trebuie distrus.
- Blocul terminal nu este inclus.
- Trebuie asigurată o împănântare corespunzătoare pe toată durata instalării.
- Pentru utilizare în exterior.
- Înlocuiți orice scut de protecție crăpat.
- Distanța minimă față de obiectele iluminate este de 1 m.



NOTĂ

- Pentru a reduce riscul de strangulare, cablurile flexibile conectate la acest corp de iluminat trebuie fixate eficient pe perete dacă se află la îndemâna mâinii.
- Pentru a menține protecția IP a produsului, intrarea cablului/presetupa trebuie instalată pe partea inferioară.



Atenție, risc de electrocutare.



Această marcă indică faptul că acest produs nu trebuie aruncat împreună cu alte deșeuri menajere.

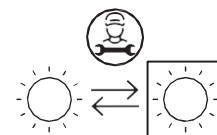

Sursă de lumină
înlocuibilă de către un

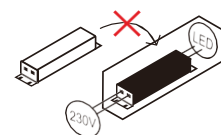

Echipament de control

DIAGRAMĂ DE INSTALARE

1

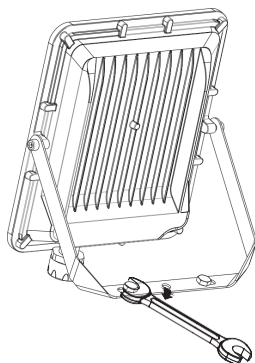

2

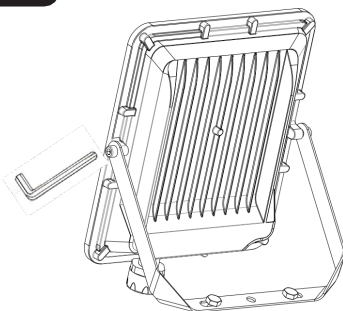

3

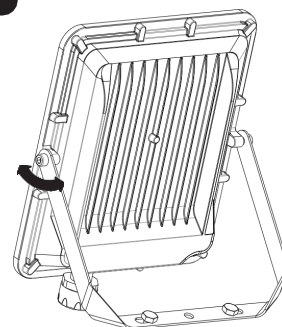

4

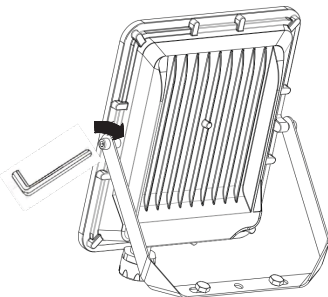

5

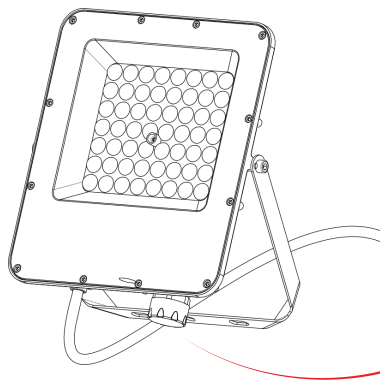

DIAGRAMĂ DE

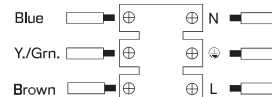

CCT
Comut

LUNGIME CABLU: 120

INSTRUCTIUNI DE INSTALARE

Important: Respectați cu strictețe pașii de mai jos în timpul instalării. Evitați să aplicați o forță excesivă asupra cablului de alimentare. Conexiunea de alimentare și alți conductori de cablare externi trebuie să aibă o secțiune minimă de 3 x 1,0 mm².

- Asigurați-vă că alimentarea cu energie electrică este oprită înainte de a începe instalarea.
- Fixați suporturile pe suprafața dorită.
- Slăbiți șuruburile de pe ambele părți ale suportului.
- Reglați proiectorul la unghiul dorit.
- Strângeți șuruburile de pe ambele părți ale suportului pentru a fixa poziția.
- Conectați cablurile proiectorului conform schemei de cablare.
- Setați temperatura de culoare dorită folosind comutatorul CCT.
- Porniți alimentarea și testați proiectorul.

INSTRUCTIUNI DE DEMONTARE

(Numai pentru echipa de supraveghere a pieței)

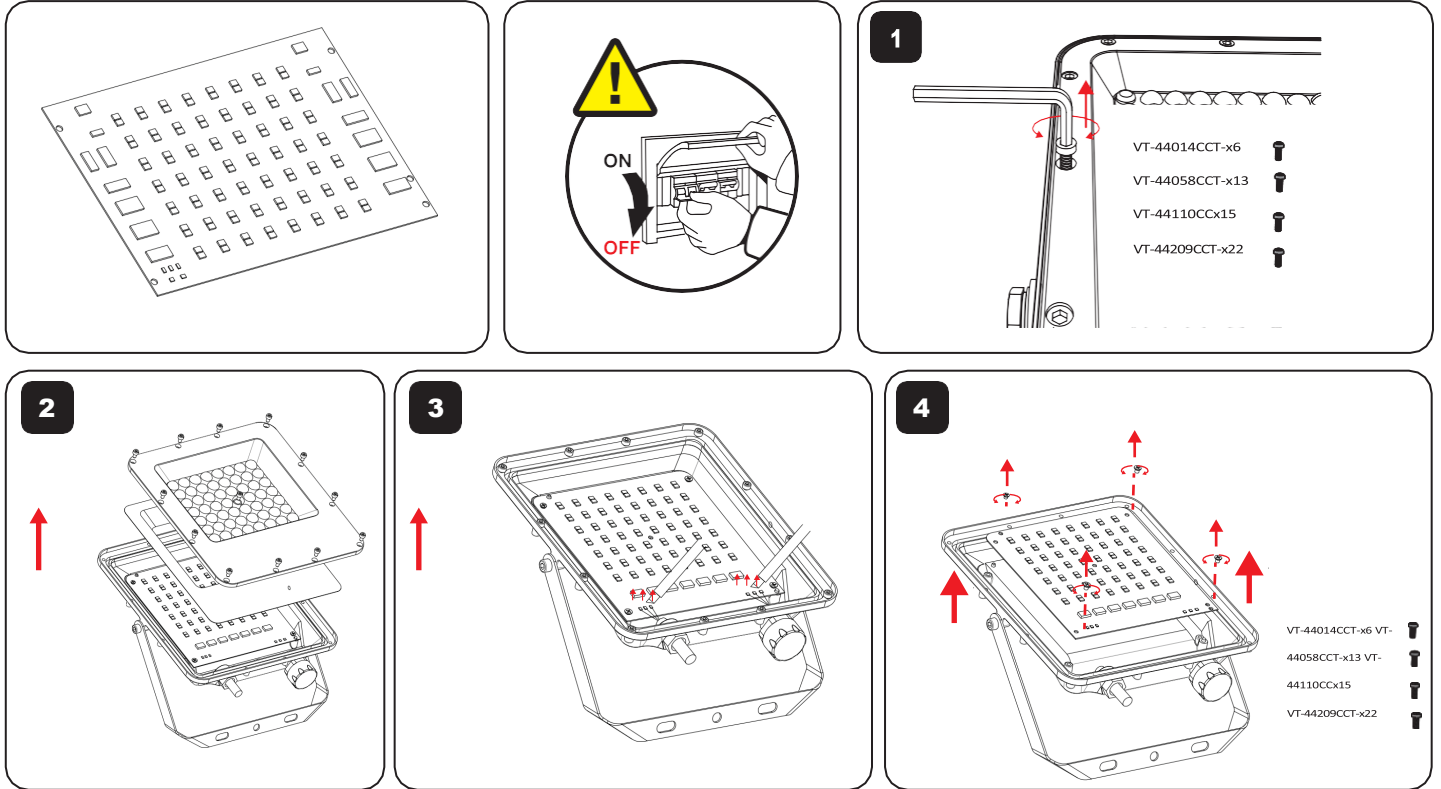

Notă: Înlăturarea sursei de lumină va anula garanția.

V-TAC WEST EUROPE LTD. ÎN CAZUL ORICĂREI ÎNTREBĂRI/PROBLEME LEGATE DE PRODUS, VĂ RUGĂM SĂ NE CONTACTAȚI LA: SUPPORT@V-TAC.EU PENTRU MAI MULTE PRODUSE DIN GAMĂ, VĂ RUGĂM SĂ CONTACTAȚI DISTRIBUTORUL NOSTRU SAU CEL MAI APROPIAT DEALER. V-TAC WEST EUROPE LTD. PARTER, 71 LOWER BAGGOT STREET, DUBLIN 02, IRLANDA D02 P593

V-TAC UK LTD. ÎN CAZUL ORICĂREI ÎNTREBĂRI/PROBLEME CU PRODUSUL, VĂ RUGĂM SĂ NE CONTACTAȚI LA SUPPORT@VTACEXPORTS.COM V-TAC, 5A TUNGSTEN PARK, DOWNS ROAD, WITNEY, OXFORDSHIRE, OX29 0AX



V-TAC

Meaningful Innovation.

MANUAL DE INSTRUCCIONES

FOCO LED



IP65
RATING

3 IN 1
CCT

DATOS TÉCNICOS

MODELO	SKU	VATIOS	LÚMEN ÚTIL (SEGUN ANCHO)	ÁNGULO DEL HAZ	VIDA ÚTIL [HORAS]	DF	CRI	VOLTAJE DE ENTRADA	DIMENSIONES	N.W	ALTURA MÁXIMA DE MONTAJE	ÁREA PROYECTADA	TIPO DE CUERPO	CLASIFICACIÓN IK
VT-44014CCT	240726	10 W	730 Lm	90	50 000	>0,9	>80	CA: 220-240 V, 50/60 Hz	147 x 33 x 122 mm	192 g	3-5 m	12-34 m ²	Aluminio	IK06
VT-44058CCT	240736	50 W	4000 Lm	90	50 000	>0,9	>80	CA: 220-240 V, 50/60 Hz	227 x 33 x 182 mm	418 g	3-5 m	18,5-50,5 m ²	Aluminio	IK06
VT-44110CCT	240716	100 W	8150 Lm	90	50 000	>0,9	>80	CA: 220-240 V, 50/60 Hz	297 x 33 x 242 mm	825 g	3-5 m	38-103 m ²	Aluminio	IK06
VT-44209CCT	240706	200 W	16450 Lm	90	50 000	>0,9	>80	CA: 220-240 V, 50/60 Hz	410 x 33 x 326 mm	1550 g	3-5 m	100-200 m ²	Aluminio	IK06

El rango de temperatura de funcionamiento de estos artículos es de -20 °C a +40 °C.

INTRODUCCIÓN Y GARANTÍA

Gracias por elegir y comprar un producto V-TAC. V-TAC le ofrecerá el mejor servicio. Lea atentamente estas instrucciones antes de comenzar la instalación y conserve este manual a mano para futuras consultas. Si tiene alguna otra pregunta, póngase en contacto con nuestro distribuidor o con el proveedor local al que le haya comprado el producto. Están capacitados y preparados para ofrecerle el mejor servicio. La garantía es válida durante 6 años a partir de la fecha de compra. La garantía no se aplica a los daños causados por una instalación incorrecta o un desgaste anormal. La empresa no ofrece ninguna garantía contra los daños causados a cualquier superficie debido a una retirada e instalación incorrectas del producto. Los productos son aptos para un funcionamiento diario de 10 a 12 horas. El uso del producto durante 24 horas al día anularía la garantía. Este producto está garantizado únicamente contra defectos de fabricación.

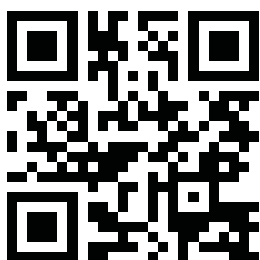

CÓDIGO QR DEL MANUAL MULTIDIÁCTO

Escanee el código QR para acceder al manual en varios idiomas.



FR

Cet appareil, ses accessoires et cordons se recyclent

À DÉPOSER EN MAGASIN

À DÉPOSER EN DÉCHÈTERIE





OU



Points de collecte sur www.quefairedemesdechets.fr
Privilégiez la réparation ou le don de votre appareil !

EN CASO DE CUALQUIER CONSULTA O PROBLEMA CON EL PRODUCTO, PÓNGASE EN CONTACTO CON NOSOTROS EN: SUPPORT@V-TAC.EU PARA MÁS INFORMACIÓN SOBRE LA GAMA DE PRODUCTOS, PÓNGASE EN CONTACTO CON NUESTRO DISTRIBUIDOR O CON EL DISTRIBUIDOR MÁS CERCANO. V-TAC EUROPE LTD. BULGARIA, PLOVDIV 4000, BUL.L.KARAVELOW 9B

ADVERTENCIA

- Asegúrese de desconectar la alimentación eléctrica antes de comenzar la instalación.
- La instalación debe ser realizada por un electricista cualificado.
- La fuente de luz contenida en esta luminaria solo debe ser sustituida por el fabricante, su agente de servicio o una persona cualificada similar.
- El cable flexible externo o cordón de esta luminaria no se puede sustituir; si el cordón está dañado, la luminaria deberá destruirse.
- Bloque de terminales no incluido.
- Se debe garantizar una conexión a tierra adecuada durante toda la instalación.
- Para uso en exteriores.
- Sustituya cualquier pantalla protectora agrietada. 
- Distancia mínima de los objetos iluminados: 1 m. 

NOTA

- Para reducir el riesgo de estrangulamiento, el cableado flexible conectado a esta luminaria deberá fijarse eficazmente a la pared si el cableado se encuentra al alcance de la mano.
- Para mantener la protección IP del producto, la entrada de cable/prensaestopas debe instalarse en la parte inferior.

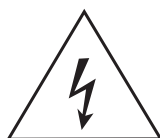
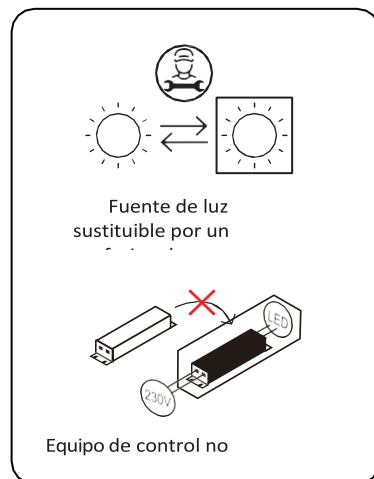

Precaución, riesgo de descarga eléctrica.



Esta marca indica que este producto no debe desecharse junto con otros residuos domésticos.

DIAGRAMA DE INSTALACIÓN

1

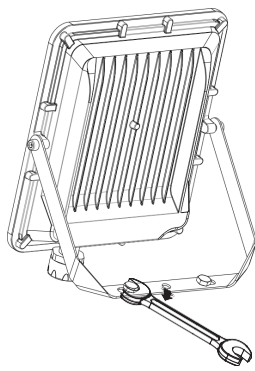

2

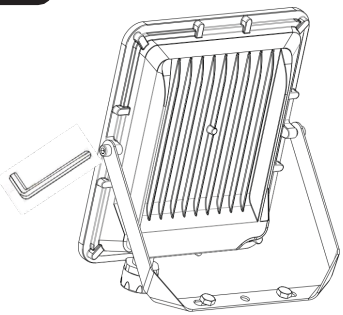

3

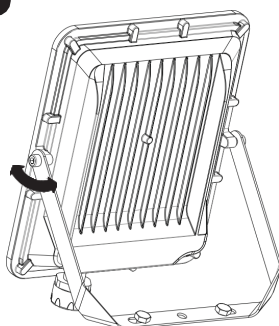

4

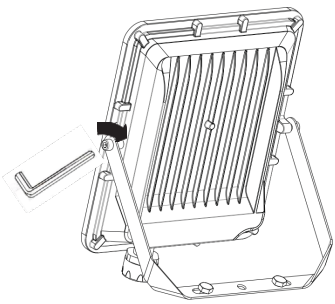

5



DIAGRAMA DE

Blue	⊕	⊕	N
Y./Grn.	⊕	⊕	⊕
Brown	⊕	⊕	L

CCT Interru

LONGITUD DEL CABLE:

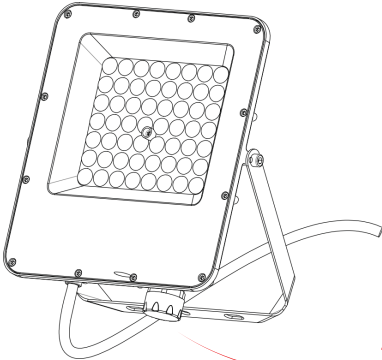
INSTRUCCIONES DE INSTALACIÓN

Importante: Siga estrictamente los pasos que se indican a continuación durante la instalación. Evite aplicar una fuerza excesiva al cable de alimentación. La conexión de alimentación y otros conductores de cableado externos deben tener un mínimo de 3 x 1,0 mm².

- Asegúrese de que la alimentación eléctrica esté desconectada antes de comenzar la instalación.
- Fije los soportes a la superficie deseada.
- Afloje los pernos a ambos lados del soporte.
- Ajuste el foco al ángulo deseado.
- Apriete los pernos a ambos lados del soporte para fijar la posición.
- Conecte el cableado del proyector según el diagrama de cableado.
- Ajuste la temperatura de color deseada con el interruptor CCT.
- Encienda la alimentación y pruebe el proyector.

INSTRUCCIONES DE DESMONTAJE

(Solo para el equipo de vigilancia del mercado)

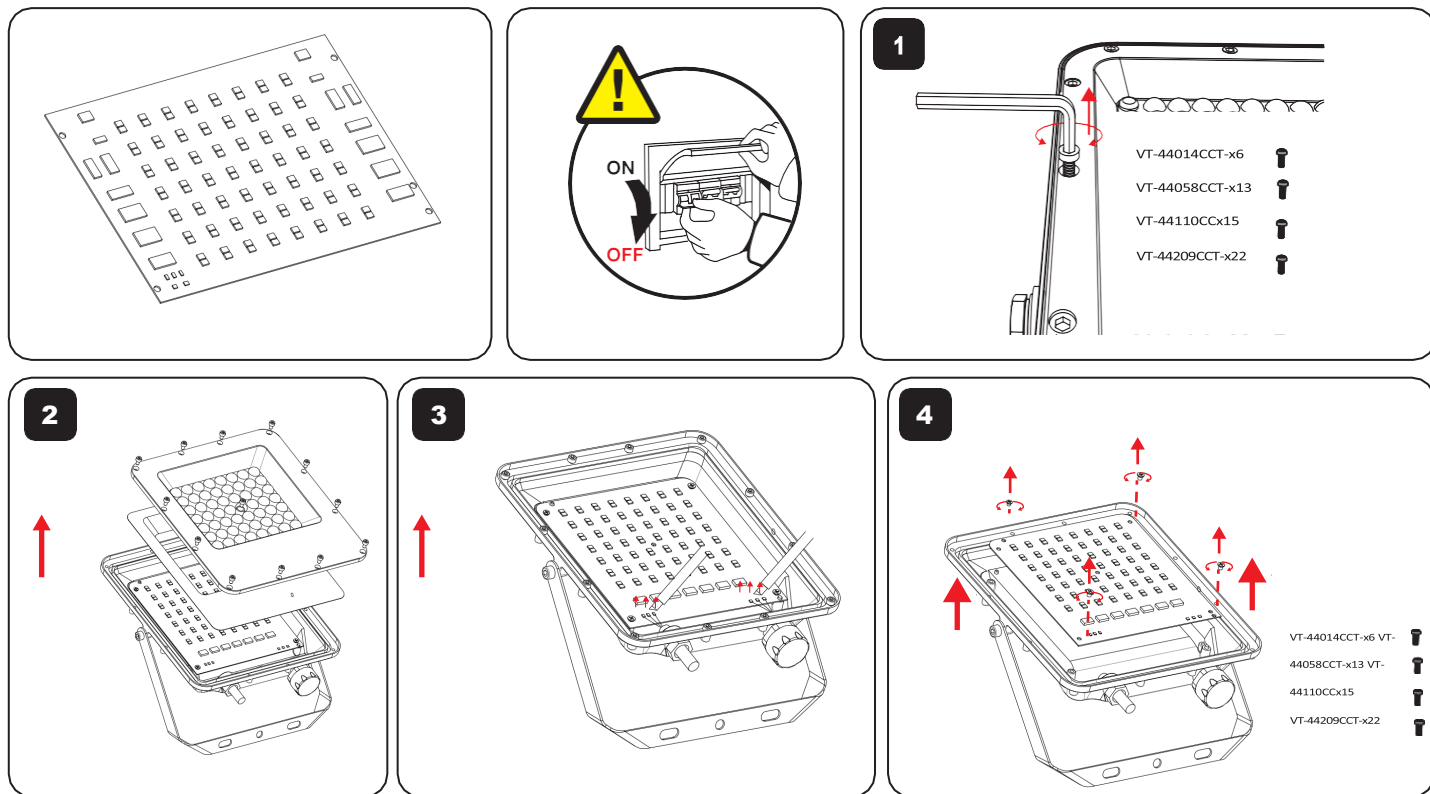

Nota: La retirada de la fuente de luz anulará la garantía.

V-TAC WEST EUROPE LTD. EN CASO DE CUALQUIER CONSULTA O PROBLEMA CON EL PRODUCTO, PÓNGASE EN CONTACTO CON NOSOTROS EN: SUPPORT@V-TAC.EU PARA MÁS INFORMACIÓN SOBRE LA GAMA DE PRODUCTOS, PÓNGASE EN CONTACTO CON NUESTRO DISTRIBUIDOR O CON EL DISTRIBUIDOR MÁS CERCANO. V-TAC WEST EUROPE LTD. PLANTJA BAJA, 71 LOWER BAGGOT STREET, DUBLÍN 02, IRLANDA D02 P593

V-TAC UK LTD. EN CASO DE CUALQUIER CONSULTA O PROBLEMA CON EL PRODUCTO, PÓNGASE EN CONTACTO CON NOSOTROS EN SUPPORT@VTACEXPORTS.COM V-TAC, 5A TUNGSTEN PARK, DOWNS ROAD, WITNEY, OXFORDSHIRE, OX29 0AX

