



Meaningful Innovation.

WEEE Number: 80133970

# INSTRUCTION MANUAL

## LED DOME LIGHT



**3** VARIABLE CCT  
3000K | 4000K | 6500K  
VARIABLE WATTS  
8W | 16W | 20W

**SUPER BRIGHT**  
**135+**  
LM/WATT EFFICIENCY

**IK 08**  
**RATING**

**CREE**  
**LED**  
**POWERED**

### TECHNICAL DATA

MODEL	SKU	BEAM ANGLE	CRI	DF	LIFE SPAN (HOURS)	INPUT VOLTAGE	MATERIAL	DIMENSION	WARRANTY	RATINIG
VT-8603	801-24-6	110°	>80	0.9	30,000	AC:200-240V, 50/60Hz	PC	320x100mm	6 Year	IP65
VT-8613	804-24-6	110°	>80	0.9	30,000	AC:200-240V, 50/60Hz	PC	320x100mm	6 Year	IP65
VT-8623	806-24-6	110°	>80	0.9	30,000	AC:200-240V, 50/60Hz	PC	320x100mm	3 Year	IP54
VT-8633	812-24-6	110°	>80	0.9	30,000	AC:200-240V, 50/60Hz	PC	320x100mm	3 Year	IP54

### SENSOR SPECIFICATIONS

MODEL	DETECTION ANGLE	DETECTION DISTANCE	DETECTION RANGE MAX.	HOLD TIME	DAYLIGHT SENSOR	MANUAL OVERRIDE	DETECTION MOTION SPEED
VT-8613 VT-8633	360° If Ceiling Mounting 120° If Wall mounting	3-6 M	D6Mx3M	5s, 30s,90s, 3min,20min,30min	Day, 2LUX,10LUX- .25LUX Optional	Available by dial switch	0.5-3m/s

### EMERGENCY SPECIFICATIONS

MODEL	EMERGENCY OPERATION TIME	EMERGENCY STANDBY WATTS	BATTERY CHARGING CURRENT	BATTERY DISCHARGING CURRENT	BATTERY TYPE	TEST BUTTON	CHARGING INDICATOR
VT-8623	>3 Hours	>1.2 Watts	250mA	410mA	LiFePO <sub>4</sub> , 3.2V, 2Ah	With	Green LED

IN CASE OF ANY QUERY/ISSUE WITH THE PRODUCT, PLEASE REACH OUT TO US AT: [SUPPORT@V-TAC.EU](mailto:SUPPORT@V-TAC.EU)  
FOR MORE PRODUCTS RANGE, INQUIRY PLEASE CONTACT OUR DISTRIBUTOR OR NEAREST DEALERS.  
V-TAC EUROPE LTD. BULGARIA, PLOVDIV 4000, BUL.L.KARAVELOW 9B

## INTRODUCTION & WARRANTY

Thank you for selecting and buying V-TAC product. V-TAC will serve you the best. Please read these instructions carefully before starting the installation and keep this manual handy for future reference. If you have any another query, please contact our dealer or local vendor from whom you have purchased the product. They are trained and ready to serve you at the best. The warranty is valid for 3 & 6 years (based on models) from the date of purchase. The warranty does not apply to damage caused by incorrect installation or abnormal wear and tear. The company gives no warranty against damage to any surface due to incorrect removal and installation of the product. The products are suitable for 10-12 Hours Daily operation. Usage of product for 24 Hours a day would void the warranty. This product is warranted for manufacturing defects only.

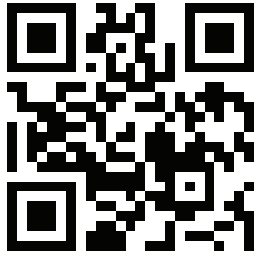

### MULTI-LANGUAGE MANUAL QR CODE

Please scan the QR code to access the manual in multiple languages.



FR

Cet appareil, ses accessoires et cordons se recyclent

À DÉPOSER EN MAGASIN



À DÉPOSER EN DÉCHÈTERIE



OU

Points de collecte sur [www.quefairedemesdechets.fr](http://www.quefairedemesdechets.fr)  
Privilégiez la réparation ou le don de votre appareil !

## WARNING

- Please make sure to turn off the power before starting the installation.
- Installation must be performed by a qualified person.
- The light source of this luminaire is not replaceable, when the light source reaches its end of life the whole luminaire should be replaced.
- If the external flexible cable or cord of this luminaire is damaged, it shall be exclusively replaced by the manufacturer or his service agent or a similar qualified person in order to avoid a hazard.

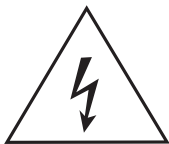

Caution, risk of electric shock.



This marking indicates that this product should not be disposed of with other household wastes.

## INSTALLATION INSTRUCTIONS

**1**

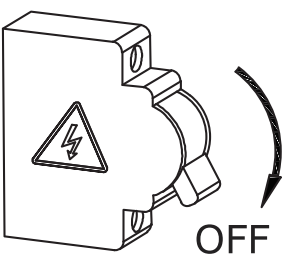

Switch OFF the power before starting the installation.

**2**

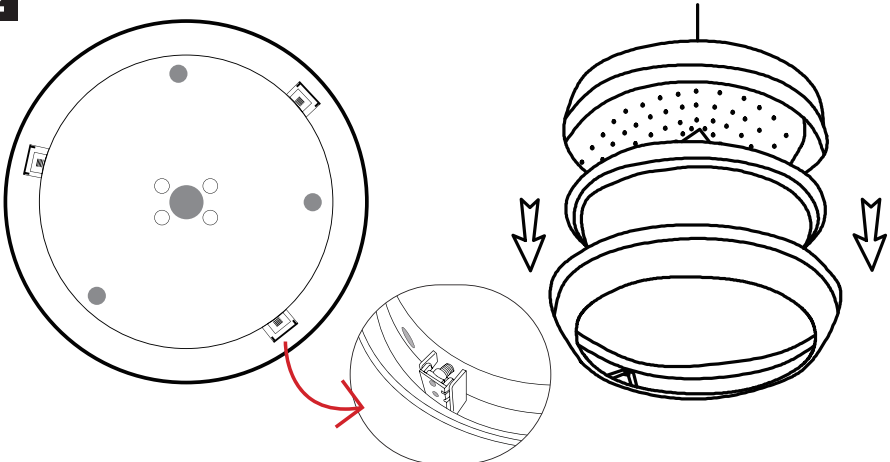

Remove the cover by holding the luminaire upside down. Press 3 clips on the sides and pull the base upwards to open and set aside.

**3**

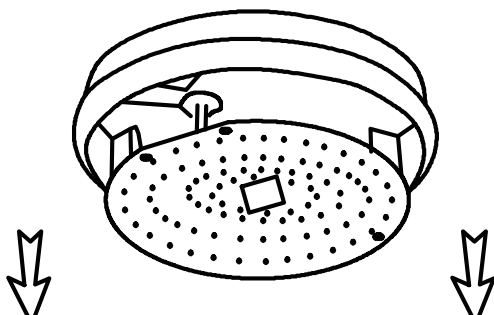

Carefully press and unlock the screw on the led hinged tray and hold the tray at an upward 90Degree position. Hold the product upside down.

**4**

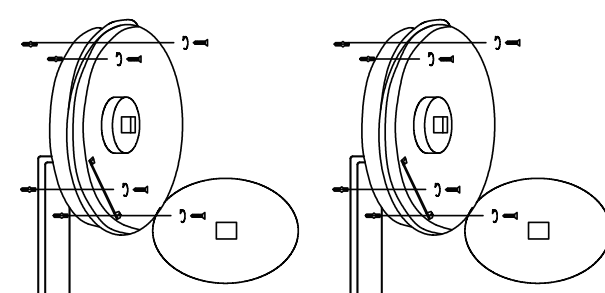

Hold the product in place, mark & drill the holes into the wall and nail the alligator into the hole. Feed the supply cable into the luminaire through the cable entry hole

**5**

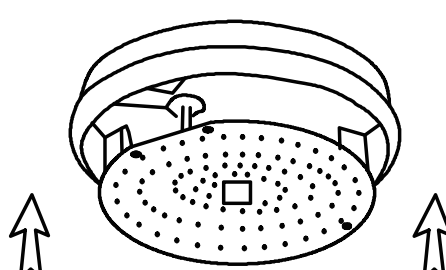

- Once the base is installed, carefully put back the hinged tray by pushing it forward.
- Hold the tray with the base and twist the screw to lock it back.

**6**

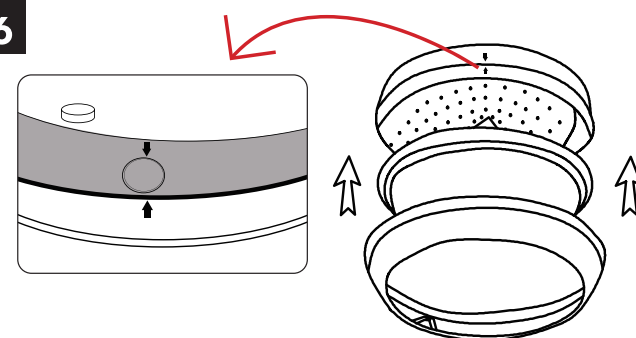

- Carefully close the cover by aligning with the marked arrows on the base ( Locate the Side conduit) and the cover to avoid breakage while closing.
- Push down from all 3 sides to properly secure the 3 clips on the sides.

**7**

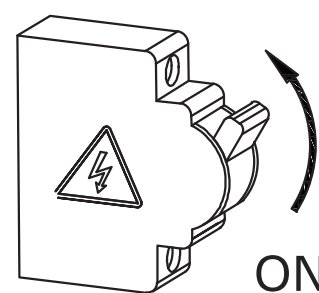

Switch ON the power to test the light.

## INSTRUCTIONS FOR CHANGING COLOR & POWER (AVAILABLE ON DRIVER)

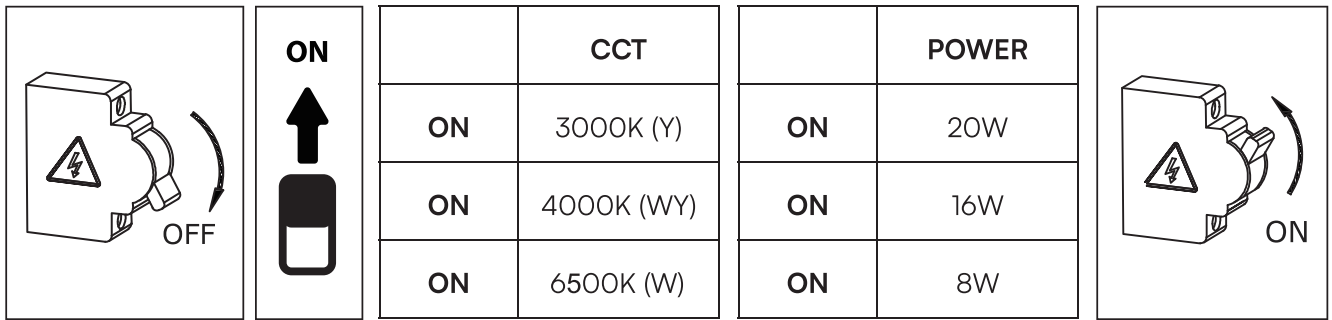

## PRE-INSTALL EMERGENCY FUNCTION TEST

- Connect the AC cable according to the diagram.
- Press the test button on the driver. The emergency function will be activated, and the charging indication will be off.
- Disconnect the battery pack, the charging indicated LED off.

NOTE: After installation, allow 36 hours to ensure full battery charge and then interrupt the supply.

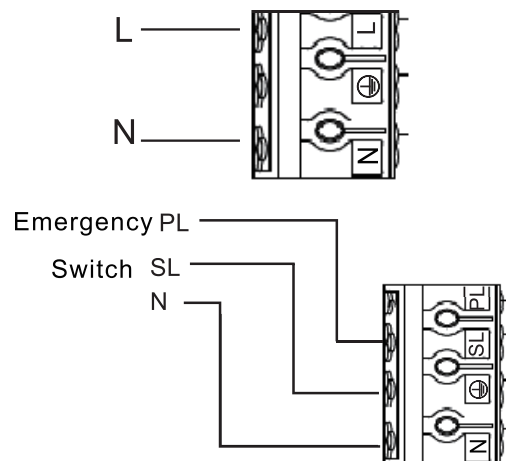

## SENSOR SETTINGS

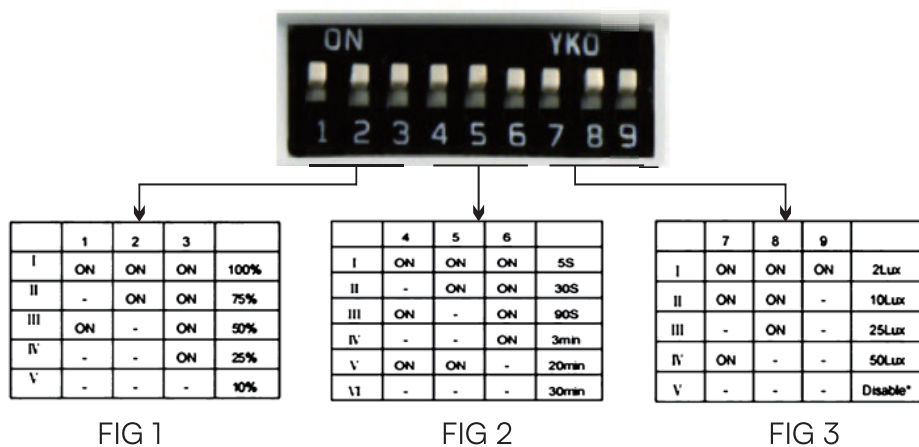

- **Detection Area** - It can be adjusted by combining DIP switches for specific application [FIG 1].
- **Hold Time** - Time period during which the light will be ON after the last detection [FIG 2].
- **Daylight Threshold** - Daylight sensor priors motion sensor. Set Threshold for Specific needs. If disabled, only motion sensor will work [FIG 3].

## APPLICATION

[FUNCTION DEMO - DIMMABLE CONTROL/CORRIDOR FUNCTION]



When motion is detected, but the daylight is sufficient, the light will remain OFF.

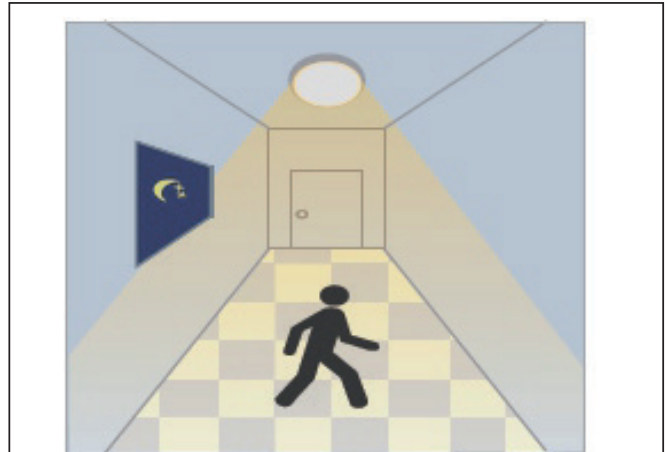

When motion is detected, and the daylight is insufficient, the light will be ON.

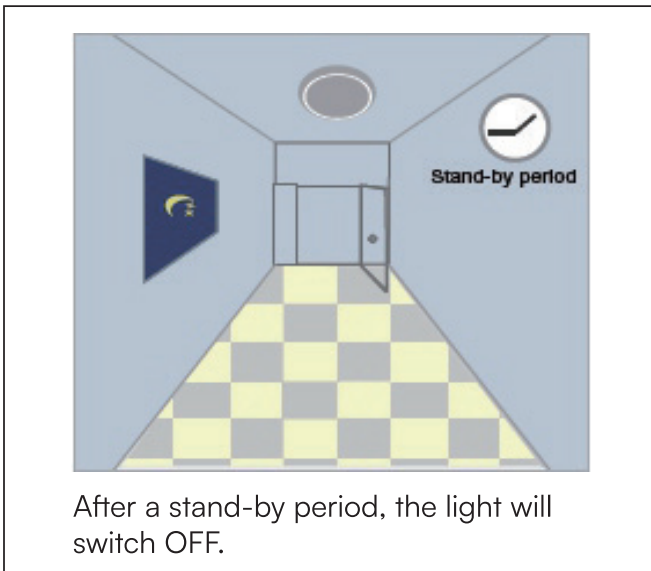

After a stand-by period, the light will switch OFF.



**V-TAC WEST EUROPE LTD.** IN CASE OF ANY QUERY/ISSUE WITH THE PRODUCT, PLEASE REACH OUT TO US AT: SUPPORT@V-TAC.EU FOR MORE PRODUCTS RANGE, INQUIRY PLEASE CONTACT OUR DISTRIBUTOR OR NEAREST DEALERS. V-TAC WEST EUROPE LTD. GROUND FLOOR, 71 LOWER BAGGOT STREET, DUBLIN O2, IRELAND DO2 P593

**V-TAC UK LTD.** IN CASE OF ANY QUERY/ISSUE WITH THE PRODUCT PLEASE REACH OUT TO US AT SUPPORT@VTACEXPORTS.COM V-TAC, 5A TUNGSTEN PARK, DOWNS ROAD, WITNEY, OXFORDSHIRE, OX29 OAX